



WEST ISLAND COLLEGE

PARENT – STUDENT HANDBOOK

Table of Contents

I. BELIEFS AND STRUCTURES

1. Statement of Beliefs
 - Organizational Values
 - Vision
 - Mission
 - Motto
2. The Philosophy of the College
3. A Brief History of the College
4. Our School Structure - A Model
5. Governance
 - Board of Governors
 - Board of Directors
 - Alumni Association
6. Board of Governors
7. School Administration
8. Personnel
9. Code of Conduct

II. PROGRAMME OF STUDY

1. Programme Philosophy
2. Junior High School Programme
3. Senior High School Programme
4. Matriculation
5. Experiential Education Philosophy

- Outdoor Education
 - Field Trips
 - Community Outreach
 - Educational Partnerships
 - Travel Study Programme
 - Class Afloat
6. Organization of Instruction
 - A Semestered Timetable
 7. Enriched Programme Philosophy
 - Junior School: Secondary I, II, III
 - Senior School: Secondary IV, V
 8. Class Assignments
 - Secondary I
 - Secondary II
 - Secondary III
 - Secondary IV & V
 9. French Programme Sequence
 10. Math Programme Sequence
 11. English Programme Sequence

III. STUDENT LIFE

1. Student Groups
 - The House System
 - Assemblies
 - The Green & Grey Society
 - House Council
 - West Island College Athletic Association (W.I.C.A.A.)
2. House Championship
3. Extra Curricular Activities
 - Clubs
4. Inter - Scholastic Sports Programme
 - Policies & Procedures
 - Pursuit of Excellence: Athletic and Academic
 - Interscholastic Sports Participation Policy
 - Academic Difficulty
 - Player Conduct
 - Transportation
 - Early Dismissals
 - Uniforms
 - Water Bottles
 - Showers
 - Tryouts, Practices and Game Schedules
 - Coaching Staff
 - Age Categories
 - Fall Season Team Tryouts
5. House League

6. Leadership Camp
7. Orientation for New Students
 - Welcome Week
 - New Student Orientation

IV. AWARDS & CEREMONIES

1. Awards

- Headmaster's List
- President's Honour Roll
- Honours' Society
- Merit Awards
- Prix d'excellence
- Ties
- Scholarships
- Athletic Awards

2. Convocation Plaques, Scholarships, Awards

- T. Barontseff Shield
- Board of Governors' Shield
- Brenhouse Shield
- Davies Family Shield
- Montreal Board of Trade
- Alexander Doucas Shield
- A.J. Grant Shield
- Melvyn Hamilton Shield
- Miller Family Shield
- Y.M.C.A. Community Service Shield
- Erlick Family Shield
- Kay Family Scholarship
- Muriel A. Davies Head Boy / Head Girl Award
- The Eakeley Shield
- The Royal Bank of Canada Shield
- The West Island College Editors in Chief "Voyages" Shield
- The McGill Science Award
- The Lakeshore Rotary Club Interactor of the Year Award
- The Lieutenant Governors' Award
- Governor General's Academic Medal and
W.I.C. Outstanding Academic Achievement Shield

3. Ceremonies

- Opening, Closing & Convocation

V. EVALUATION & COMMUNICATION

1. Evaluation

- Philosophy

- Report Cards
 - * Report Cards Intent
 - * Format
 - * Sample Report Card
 - * Report Card Interpretation
 - ◊ Semester or Term
 - ◊ Course Evaluation Section
 - ◊ Calculation of the Final Grade (mark)
 - * Effort Rating
 - * Effort Grade Average
 - * Academic Average Calculation
 - * Citizenship Evaluation

2. Communication

- Newsletters, Notices & Website
- Report Cards
- Carnet de l'élève
- Agenda Signing
- Telephone: Who to Call?
- Telephone Availability: Students
- Parent Information Evenings
- Parent Teacher Interviews
- Change of Address or Telephone Number
- Electronic Mail
- Internet Web Page
- On-Line Marks Consultation

VI. RULES, POLICIES, SANCTIONS

1. Foundations for Success at school: Expectations, Obligations, and Responsibilities
2. School Rules
3. Sanctions
4. Uniform
 - Description
 - Supplier
5. Policies
 - Promotion Policy
 - Absentee Policy
 - * Late Arrival or Early Departure
 - * Granting Credits
 - * Examinations
 - * Assignments
 - Incomplete Mark Policy
 - Examination Environment Policy
 - Detention Policy

- Senior High School Course Load Policy
- Visitors Policy
- Homework Time
- Evaluation Coordination Practices
- Leaving School Grounds
- Student Drivers, Parking, Bicycles
- Smoking
- Snow Days or School Closing

VII. SERVICES

1. Extra - Help
2. Tutoring
 - Peer tutoring
 - Professional tutoring
3. Study Hall
4. Guidance
5. Library Resource Centre: Computer Services
6. Books
 - New Textbooks
 - Used Textbooks
7. School Supplies
8. Photographs
9. Transportation
10. Bus Passes
11. Cafeteria Services
12. Lost & Found

VIII. THE SCHOOL YEAR

1. The School Day
 - Daily Assembly
 - School Hours
 - Semestered Timetable
 - Timetable Flip
 - Daily Timetable
2. The School Calendar
3. The Year at a Glance

I - Beliefs and Structures

1. Statements of Belief

WIC's Organizational Values

At WIC we believe that

- ◆ excellence is achieved by developing one student at a time
- ◆ inspired teachers broaden students' horizons
- ◆ individuals gain respect by respecting others
- ◆ languages open doors to the world
- ◆ proactive curriculum prepares our graduates to succeed in an ever-changing world

WIC'S Vision

West Island College is a multicultural community of learners, focused on the education of the complete individual. At WIC, we are committed to the pursuit of excellence, fostering a passion for knowledge and instilling fundamental values

that empower our students to succeed in the ever challenging environment of today and tomorrow.

MISSION

At West Island College, our mission is to prepare our graduates to excel in post-secondary education and in life through academic achievement, community service, experiential learning and co-curricular involvement in a bilingual learning environment.

September 2006



Motto

Praestantium Consectemur
"The Pursuit of Excellence"

2. The Philosophy of the College

All children love to learn and the satisfaction derived from working to one's potential can seldom be equaled. The excitement of new discoveries and new ideas, the entirely new dimension of a second language used as the vehicle of instruction, and the development of responsible and independent thought are qualities and experiences that West Island College extends to its students.

At the school, all programs are directed toward the full development of the individual student. This is achieved through a fine balance of academic, physical, and character-building programs. Small classes and a professional staff, which really cares about young people, provide the enriched environment that allows students to achieve their very best.

Although West Island College is non-denominational, the development of sound ethics, moral values, and social responsibility is given significant attention. While the College recognizes that values cannot be imposed, it does feel that values can be properly exposed. The school would be neglecting an important function if it were to ignore this area of education.

3. A Brief History of the College

West Island College was founded in 1974 by Terry D. Davies, in response to the need for an academic programme dedicated to preparing students for post secondary studies and for the reality of contemporary Canadian society. The College was first established in Pointe-Claire, Quebec, and has since moved to Dollard-des-Ormeaux, Quebec, which is situated in the West Island region of Montreal. Throughout the College's history, it has met with outstanding success in each of its pursuits. This fact is easily substantiated by the College's rapid growth. The original campus, from a modest genesis of 40 students, now accommodates 440 students in a custom-built school.

With a continuing commitment to the balanced academic and social growth of young Canadians, West Island College embarked on an ambitious programme of expansion. In 1982, West Island College of Alberta opened in Calgary. Dedicated to the same principles and precepts as the Montreal school, it has developed in a like fashion. Indeed, in comparing the schools' early histories, a remarkably similar growth pattern is noted. From a group of 39 students, the Calgary College now boasts a population of over 380 students.

West Island College recognizes the need for a broader education and the inherent value of national and international perspectives; through the creation of regional campuses and Class Afloat, it is actively involved in the pursuit of same.

Class Afloat, founded in 1985, is a co-educational sailing programme, combining accredited academic classes for Senior High School and gap year students, with one semester or two of world travel aboard a tall ship. It is the ultimate experiential

educational trip and, therefore, a further manifestation of the West Island College philosophy.

4. Our School Structure - A Model

The model of a traditional school structure has students at the base of a large pyramid with teachers and administrators stacked in layers on top of them. In this structure there is little accommodation made for parents, little chance for teachers to influence organizational directions and, most sadly, precious little opportunity for students to impact the decisions which affect their education. At the College it is our considered opinion that this structure does not serve the educational needs of students and, consequently, we have developed one which we feel takes advantage of the talents and interests of the various constituents playing a role in the child's growth.

Former Calgary Headmaster, Perry Bedard, created a model as a concrete representation of our school's structure. The model (next page), positions administrators, teachers and parents as three spheres of influence contributing to a child's development. Students, at the nucleus of the model, occupy a place which permits the adults in their lives to teach and support without being domineering. From this central position our students have the chance to be seen and to be heard; they have an opportunity to contribute to the quality of their own education.

For our structure to be successful, however, there must be an understanding by all parties of the role that they play. There must also be a willingness by all to assume ownership for their role. The adults must recognize that in this model the intellectual and emotional welfare of the child must be their singular concern. Students must accept that education is a dynamic process to which they must actively contribute in order to gain the maximum from the experience.

Jere Brophy in Educational Leadership (October 1987) indicated that children acquire competence "through modelling, communication of expectations, and direct instruction or socializing by significant others (especially teachers and parents)".

The beliefs teachers themselves have about teaching and learning and the nature of the expectations they hold for students exert a powerful influence on them. Deborah Stipik, in Motivation to Learn: Theory to Practice (1988), notes that "to a very large degree, students expect to learn if their teachers expect them to learn".

Schoolwide goals, policies, and procedures (the domain of administrators) must interact with classroom climate, and practices to affirm or alter students' learning related attitudes and beliefs.

A child's home environment shapes the initial constellation of attitudes he/she develops towards learning. When parents nurture their children's natural curiosity about the world by welcoming questions, encouraging exploration, and familiarizing them with resources that can enlarge their world, they are giving their children the message that learning is worthwhile and frequently fun and satisfying. If the home environment nurtures a sense

of self-worth, competence, autonomy and self-efficacy, children will be more apt to accept the risks inherent in learning.

THE WIC MODEL

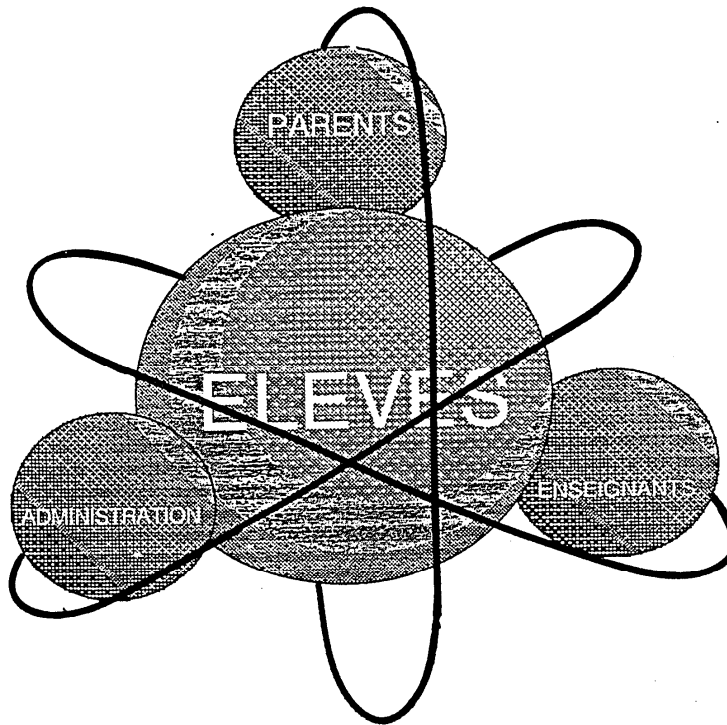

5. *Governance*

West Island College, founded in 1974, is incorporated as a non profit company. It owns all its own property, buildings and equipment.

- **The Board of Governors**

The Board of Governors of West Island College is the seat of all governance in the school. It provides advice to the Head of the School, to the Business Manager and to the Directors and Officers on any matter respecting the school. It also assists with communications between the school, the Directors, the Officers and the Parents. It may, in its sole discretion, carry out surveys or other forms of feedback on school operations, parent and student satisfaction and any other matters.

- **The Board of Directors**

The Board of Directors of the Corporation shall consist of five (5) directors, each being a member of the Board of Governors of the Corporation.

- **Alumni Association**

The West Island College Alumni Association is an active partner in the management of the College. With representation on the Board of Governors, more than 1800 graduates are members of the Association. Each year, the membership donates a substantial amount of money to the College. These funds, used exclusively for the improvement of buildings and grounds, scholarships and financial aid to students, specialized teaching materials, special equipment and research and development, are critical to the school's future growth.

6. The 2008-2009 Board of Governors

Chairperson:	Mark Goldman
Vice Chairperson:	Keren Mann-Knopp
Founder:	Terry Davies
Honorary Patron	Jane Goodall
School Administrator:	Martin Bailly
Faculty Representative	Émilie Simard
Secretary/Treasurer:	Howard Messias
Parent:	Cynthia Aboud
Parent:	Karen Goldman
Parent:	Mercedes Muhlegg
Parent:	Marla Wexler
Member at Large:	Eddy Prorok
Member at large:	Mitch Kastner
Past Chair:	David Holzmuller
Alumnus:	Robert Sternszus
Alumna:	Nadia Sabri
Alumna:	Tara Saxe

All meetings begin at **19h30**. All members of the College are welcome to join these assemblies as observers. The dates for the meetings are published annually in the Au Courant Newsletter and in the School Calendar.

If you desire to become active in your child's school and help make a difference we encourage you to do so by joining the Board of Governors or any of the Board of Governors' committees. To join a committee or indicate your desire to volunteer in any other way, simply contact the Headmaster.

7. School Administration

At West Island College, five administrators, working as a team, serve the school community. Their specific responsibilities are tailored to the needs of the different stakeholders within that community. Learning at West Island College implies a shared

commitment by teachers, students, parents and administrators. Our organigram facilitates the placement of students at the centre of a nuclear structure around which three influential spheres orbit: parents, teachers & administrators.

Our school's management structure is comprised of the following individuals:

Headmaster: Mr. Martin Bailly

Director of Studies: Mr. Jamie Henderson

Director of Student Services: Mr. Robert Reid

Director of Operations: Ms. Lise Lafontaine

Should you wish to speak with an administrator, please feel free to call or make an appointment. We look forward to getting to know you and your family so that we may better serve your child. While any one of this group welcomes the opportunity to meet and speak with you, the following description of responsibilities is intended as a helpful guide to contacting the person best placed to help you.

The Headmaster:

The overall delivery of our services to students and parents with overall responsibility of teaching personnel. The Headmaster is the guardian of school culture and its educational leader. Specifically, the Headmaster oversees the social and academic growth of "senior school" students, assumes responsibility for the evaluation, selection and dismissal of faculty, supervises the Director of Studies, the Director of Student Services and the Director of Technology.

The Director of Studies:

The social and academic progress of Secondary I students, curriculum development, evaluation of students, teaching materials, curriculum supervision (content and pace), and timetabling.

The Director of Student Services:

The social and academic progress of Secondary II & III students, extra-curricular activities, outdoor education, physical education, and student government.

The Director of Operations:

Responsible for budgets, finance, banking and legal matters; all external communications, overseeing all special events, developing and implementing annual marketing plans including development strategies (fundraising).

8. *Personnel 2008-2009*

Administration

- » **Mr. Martin Bailly, B.Ed, D.E.S.S.** [Headmaster]
- » **Mr. Jamie Henderson, B. Ed., M.Ed.** [Director of Studies]
- » **Mr. Robert Reid, B.P.H.E.-B.A., B. Ed., M.Ed.** [Director of Student Services]
- » **Ms. Lise Lafontaine, B. Com., M.B.A.** [Business Manager]
- » **Mrs. Teresa De Luca** [Accountant]
- » **Mrs. Karen Read** [Special Events Officer]
- » **Mrs. Amanda Wener.** [Alumni and Development Officer]
- » **Ms. Jennifer Neill, B. Com.** [Marketing and Admissions Officer]

Student Services

- » **Mrs. Geneviève Claver** [School Secretary]
- » **Ms. Mirella Dell'Aquila** [Receptionist]
- » **Mrs. Julie Hunt** [Receptionist]
- » **Ms. Emma Mangas, B.Sc., D.E.S.S.** [Lab Technician]
- » **Mrs. Kimberly Wolfe, B.A.** [Guidance Counsellor]

Building & Grounds

- » **Mr. Réjean Larrivé** [Building Superintendent]

Faculty

- » **Mr. Moustafa Al-Hilli, B. Ed.** [Science]
- » **Mrs. Sandra Alves, B.A., B. Ed.** [French]
- » **Mrs. Daryl Ann Bambic, B.A., M. Ed.** [Master Educator - English & Spanish]
- » **Mrs. Gaétane Baraby, B.A., B. Ed., M. Ed.** [Master Educator – French & social Sciences]
- » **Mr. David Bélanger, B.A., B. Ed., B. Com.** [Mathematics]
- » **Mrs. Tessa Berger, B.A., Dip. Ed.** [Master Educator –English]
- » **Mrs Aline Blain,, B. Ed.** [French]
- » **Mr. William Bowles, B. Music, Dip. Ed.** [Master Educator - Music]
- » **Mr. Claude Brais, B. Sc., Dip. Ed.** [Master Educator - Social Sciences]
- » **Mrs. Chantal Buzaglo, B. Sc., B. Ed.** [Master Educator - Mathematics]
- » **Mrs. Vincenza Caldereri, B.F.A., M.A., Dip. Ed.** [Master Educator - Art]
- » **Ms. Annick Choquette, B. Ed.** [French]
- » **Mr. Paul Dias, B. A., Dip. Ed.** [English]
- » **Ms. Maryse Dion, B. Ed.** [Master Educator - French & Spanish]
- » **Mr. Ted Duchêne, B. Ed., B.A.** [Mathematics]
- » **Ms. Annie Garneau, B. Ed.** [French & Social Sciences]
- » **Mrs. Christina Grivas, B. Ed.** [English]
- » **Ms. Sandra Johnson, B.Ed.** [Physical Education]
- » **Mrs. Eniko Kiefer, B.A., Dip. Ed., M.T.M.** [Master Educator – Mathematics]
- » **Mrs. Annie Krespil, B.A., B. Ed.** [English]
- » **Mr. Andrew Lee, B. Ed., B. Comp. Sci.** [Mathematics & Science]
- » **Mr. Christopher Leone, B. Ed.** [Social Sciences]
- » **Mr. Jean-Pierre Mailloux, B. Ed.** [Physical Education]
- » **Mr. Chris Merritt, B. Ed., B.A.** [Student Life Animator]
- » **Mrs. Maryse Msika, B. Ed.** [Master Educator – French]
- » **Ms. Fiona Myers, B. Ed.** [English]
- » **Mr. Élie Nader, B. Ed., Civil Eng.** [Master Educator - Mathematics]
- » **Mr. Patrice Nantel, B. Sc., Dip. Ed.** [Master Educator - Science]
- » **Mr. Glenn Neill, B. Ed.** [Civics, Physical Education]
- » **Mrs. Margaret Pitcher, B. Ed.** [Master Educator - English]
- » **Ms. Marie-Joëlle Rhéaume, B. Ed.** [Mathematics]
- » **Mr. Roger Robidoux, B. Sc., M.Sc., MBA** [Mathematics]
- » **Mrs. Carol Rolland, B. Ed.** [French]
- » **Mr. Gilles Roussin, B. Sc., Dip. Ed.** [Science]
- » **Ms. Cindy Segal, B.A., B. Ed.** [English]
- » **Ms. Emilie Simard, B.A.** [Master Educator – French]
- » **Mr. Allan Tabatchnick, B.Sc., Dip. Ed., M. Ed.** [Science & Mathematics]
- » **Mr. Jason Thompson, B.A., B. Ed** [English]
- » **Mrs. Valerie Vien, B. Sc., B. Ed., Grad. Dip.** [Master Educator - Science]

9. Code of Conduct

Students, teachers, and administrators contributed to the creation of a school Code of Conduct. The Code is not a set of rules, but rather a description of the qualities and actions all members of the school community (parents included!) must strive toward in order that the same school community, and its members may thrive, both academically and socially. In the end, this Code must not become something one reads and then discards, but rather a compass one continually refers to for direction, both in and out of school.

We at West Island College are responsible for who we are.

Everyone has a part in keeping our environment clean and safe.

Shaping our surroundings through care and involvement,

Together we are working to make our school a welcome place.

Inside and outside the classroom, we all want the same thing:

Students and staff treating each other with respect.

Listening when others are speaking is common courtesy.

Appreciation of diversity enriches our lives.

Niceties and encouragement, rather than criticism, are welcomed by all.

Developing friendships is one of the most memorable parts of school life.

Committed to doing the best that I can,

Open-minded with regard to others' ideas and opinions,

Levelheaded when frustrated or upset,

Learning to treat others as I would like them to treat me,

Eager for new ideas, for new challenges,

Grateful for the special things that people do for me:

EXCELLENCE - this is what I want; this is what I strive to attain.

II - Programme of Study

1. Programme Philosophy

West Island College is dedicated to providing its students with the most comprehensive and relevant academic programme possible. The College recognizes and accepts the tremendous responsibility it has in guiding young people in their decision-making, particularly as this decision-making relates to their future academic careers. In the pursuit of its vision, the College offers to its students an enriched academic programme that has been designed to allow them to explore a variety of fields and thus make informed and intelligent decisions when entering college.

West Island College's programme also reflects its commitment to an education that draws on the values of the past, recognizes the reality of the present and prepares for the demands of the future. In keeping with the school's philosophy of providing our students with enriching hands-on experiential programmes outside the classroom, several intriguing community outreach and educational partnership programmes have been designed for the mature senior student. These programmes supplement an academically demanding core curriculum.

Our core curriculum is designed to provide a sound and enriched foundation in languages, the social and physical sciences and mathematics. Rather than offer advanced courses to the chosen few, we offer advanced level courses to all our students. Experience and ministry examination results indicate that this approach is well suited to our students. Requiring all our students to become involved in school life and in the broader community through programmes such as Community Outreach has aided our students to acquire the life skills required for success.

Our goal is to provide for our students a curriculum and methodology that will develop the skills required to enter, and graduate successfully from, college.

2. Junior High School Programme of Study

“Building A Solid Foundation”

West Island College offers the students of its Junior School a choice between two programmes of study.

1. Studies in French

This curriculum is designed for students who, during their elementary school education, opted for French immersion studies, or attended French schools. Students enrolled in this curriculum follow their core programme in French.

2. Studies in English with Enriched French Studies

This curriculum is designed for students who have followed either English or French programmes in elementary school and who are ready to accept the challenge of learning a second language. Students enrolled in this curriculum follow their core English, Mathematics and Science courses in English and complementary courses in French.

Graduates of either programme may earn the West Island College Certificate of Bilingualism.

Secondary I

English Language Arts
Français langue d’enseignement
Mathematics / Mathématique
Science & technologie / Science &
Technology
Géographie
Histoire et éducation à la santé
Éducation physique et à la santé
Arts plastiques / Visual Arts
Musique / Music
Méthode d’étude / Study Methods
Informatique / Computer Methods
Enseignement moral / Moral Education
Formation plein air / Outdoor Education

Secondary II

English Language Arts
Français langue d’enseignement
Mathematics / Mathématique
Science & technologie / Science &
Technology
Géographie
Histoire et éducation à la santé
Éducation physique et à la santé
Arts plastiques / Visual Arts
Musique / Music
Espagnol - Spanish
Enseignement moral / Moral Education
Formation plein air / Outdoor Education

Secondary III

English Language Arts
Français langue d’enseignement
Français langue seconde enrichi
Mathematics / Mathématique
Science & technologie / Science &
Technology
Histoire et éducation à la santé
Éducation physique et à la santé
Arts III
Formation plein air / Outdoor Education
Option: Espagnol, Musique, Théâtre,
Math Plus

3. Senior High School Programme of Study

“A University Preparatory Curriculum”

It is our belief that the best way to prepare for the future is to capitalize on the opportunities of the present. With this in mind, West Island College offers an enriched curriculum to all its students during their years in high school. Time is provided during the school day for students to commit themselves to community service, to develop “career opportunities” through guest lectures, job placement opportunities and individual research, and to participate in structured explorations of cultural, academic or personal interests.

As further evidence of the College’s commitment to preparing students for post secondary studies, courses in the Senior School are taught in a semestered timetable similar to college programmes.

LANGUAGES

English Lang. Arts IV
English Lang. Arts V
Français lang. maternelle IV
Français lang. maternelle V
Français Immersion IV¹
Français Immersion V¹
French Sec. Language IV
French Sec. Language V
Espagnol IV-V¹
Conversational Spanish V¹
Interactive English V¹
Mandarin IV-V
Journalism / Journalisme V
Français V+ Tutorial V¹
English V+ Tutorial¹

MATHEMATICS

Mathématiques 416/426/436
Mathematics 416/426/436
Mathématiques 536
Mathematics 536
Mathématiques 526
Mathematics 526
Intro Calculus V¹
Mathématiques préparatoire 426/436 IV¹
Mathématiques 536+ Tutorat V¹
Mathematics 536+ Tutorial V¹

SCIENCE & TECHNOLOGY

Physical Sciences 416/ 436
Science Physique 416/ 436
Environmental Biology IV-V¹
Chemistry 534¹
Chimie 534¹
Physics 534¹
Physiques 534¹
Méthodes scientifiques V¹
Scientific Methods V¹
Robotique /Robotics V¹
Computer Projects & Programming V¹
Projets en informatique & programmation V¹
Info-affaires
Professional Presentations & E-Business
Science Careers Practicum V¹
Carrières scientifiques V¹
Environmental Leadership Practicum V¹
Leadership environmental V¹

ARTS

Media Lit. & Production IV-V¹
Média IV-V¹
Contemporary Film Studies V¹
Cinéma V¹
Théâtre IV-V
Visual Art & Ceramics IV-V¹
Arts & céramiques IV-V¹
Music / Musique IV-V¹
Montréal Culturel V¹
Practicum Arts V¹

SOCIAL SCIENCES

Histoire du Québec & Canada IV
History of Quebec & Canada IV
Histoire contemporaine mondiale V^{1 2}
Global Politics & Issues V¹
Politique & événements mondiaux V¹
Introduction à la psychologie V¹
Introduction to Psychology V¹
Philosophy for Teens V¹
Intro. Sociologie & anthropologie V¹
Intro to Sociology & Anthropology V¹
Éducation économique V
Economics V
Introduction to Business IV-V¹
Affaires IV-V¹
Commerce Practicum V¹
Practicum en affaires V¹

PERSONAL DEVELOPMENT

Ethics & Religions IV / Éthique & religions IV
Community Outreach IV²
Career Choices / Choix de Carrière IV-V
Éducation Physique / Life Sports IV^{2 3}
Éducation Physique / Life Sports V²
Option Éducation physique V¹
Leadership sportif V^{1 2}
Formation plein-air / Outdoor Education IV-V²
Option plein-air plus V^{1 2}
Voyages internationaux / International Travel
Practicum sur mesure V^{1 2}
Self-Designed Practicum V^{1 2}

¹ Option Course

² An Off-Campus Programme

4. Matriculation Criteria

Matriculation Criteria for graduates of 2008 & 2009

Ministry of Education Secondary School Diploma Leading to Post-Secondary Studies

- 54 credits obtained at the Sec IV & V level, 20 of which must be Secondary V.
- 6 Secondary V mother tongue credits
- 4 Secondary V second language credits
- 4 credits for History of Quebec & Canada
- 4 credits of Secondary V level math or an equivalent (Mathematics 426 or 436)
- 6 credits of Physical Science 416 or 436

Ministry of Education Matriculation Criteria Requirements as of 2010

- 54 credits obtained at the Sec IV & V level, 20 of which must be Secondary V.
- 6 Secondary V mother tongue credits
- 4 Secondary V second language credits
- 4 credits for History & Citizenship
- 4 credits of Secondary IV Mathematics
- 4 credits of Secondary IV Science & Technology
- 2 Secondary V credits in Arts
- 2 Secondary V credits in Personal Development

West Island College High School Diploma

Satisfaction of all Ministry of Education criteria for a High School Diploma Leading to Post-Secondary Studies and in addition:

- 12 additional credits obtained at the Secondary IV or V level.
- Completion of the West Island College Personal Development Programme (Community Outreach & Outdoor Education)
- One extra curricular activity for each year of study at West Island College

West Island College High School Diploma with Distinction

Satisfaction of all West Island College High School Diploma criteria and, in addition:

- The Headmaster's List * in each of Secondary IV & V.

West Island College High School Diploma with Great Distinction

Satisfaction of all West Island College High School Diploma with Distinction criteria and in addition:

- The President's Honour Roll ** in each of Secondary IV & V.

West Island College Certificate of Bilingualism

The W.I.C. Certificate of Bilingualism is awarded to all graduating students who have successfully completed Secondary V English and either of the Secondary V Français langue maternelle programmes: *Français langue maternelle 5e secondaire* OR *Français Immersion V*.

* The Headmaster's List is an honour roll to recognize effort commensurate with ability, school citizenship and involvement in extra-curricular activities. To qualify for the annual list, one must have qualified two terms.

** The President's Honour Roll recognizes students who maintain an academic average equal or superior to 85%.

5. *Experiential Education Philosophy*

The philosophy of Experiential Education is obvious from its name - education through experience. Rather than learning through textbooks, lectures, or classroom simulations, experiential education advances learning by directly involving students in new and dynamic experiences. As a teaching strategy, student experiences become enriched by their involvement in the planning, preparation, execution and follow-up activities as much as possible. The junior student lives this experience primarily through Outdoor Education, Field Trips, Extra-Curricular Activities, and Interscholastic Sports. The Senior Programmes of Community Outreach, Leadership, and Field Practica in Science, Social Science and Commerce are further examples of our application of this teaching strategy.

• *Outdoor Education*

The outdoors offers many possibilities for the development of the child. Each student stands to benefit:

- By contributing positively to group discussions and tasks.
- By personally experiencing the results of decisions they took part in.
- By learning skills that allow students to move safely and comfortably in the wilderness environment.
- By developing the skills necessary so that by the final year students can plan their own excursions.
- By imbuing an aesthetic appreciation for the wilderness. Possibly, this could result in students taking steps to preserve it.

In addition to all of these, a more immediate objective is the hope that sharing such an intimate and dynamic experience will help to strengthen relationships amongst students and with teachers. There is something very humanizing about eating and sleeping, laughing and singing, and winning and failing together. When the trip is over and everyone returns to the classroom, teachers and students may share a new understanding and respect. This alone makes the trip a worthy experience.

• *Field Trips*

The philosophy of Experiential Education extends to the individual classrooms as well as the outdoors. Teachers are encouraged to seek ways by which they can bring the curriculum alive. Visits to the theatre, the concert hall and museums are fostered and encouraged. Programs of Outreach, Partnerships, and Leadership are also manifestations of this philosophy.

- ***Community Outreach***

All students at West Island College are required to undertake community volunteer work whilst in Secondary IV. During the second semester, one afternoon a week is devoted exclusively to our Community Outreach Programme. After first semester preparation, students go out into the real world to various shelters, schools, old age homes, etc. Students work directly with on site personnel and gain a wealth of experience and insight.

Commitment, responsibility and leadership with humility are but a few of the skills developed with this experiential programme.

- ***Educational Partnerships Programme***

Expanding on the Outreach programme's philosophy of hands-on learning, the Educational Partnerships programme provides our Secondary V students with the opportunity to gain experience in the working world through a practicum in the discipline they intend to study at college. Sec. V students may opt to do a practicum in Science, Commerce, Sports Leadership or design their own practicum experience. By spending some time with a health practitioner, engineer, or building a business with a group of colleagues, our students gain a better understanding of the skills, duties, aptitudes and educational backgrounds needed for a variety of careers. This opportunity to explore the world of work in turn enables students to make realistic and informed decisions about their futures.

- ***Travel Study Programme***

Each year West Island College organizes exciting Travel Study opportunities for interested Secondary III, IV and V students. Information as to the destination is announced annually in the fall of the academic year. These trips have different objectives and themes: Discovery of Cultures, Ecology and Nature, Arts, History, Student Exchanges and Sports. Past destinations have included France, England, Italy, Spain, Greece, Germany, Costa Rica, United States, Kenya, Thailand, and Argentina. China and Tunisia are among countries on our list of future potential destinations for upcoming trips. The world is ours to discover. Our motto is "Learn to travel, travel to learn".

- ***Class Afloat***

Operating since 1985, this truly unique and exciting programme is available to Secondary V and CEGEP students. Full accreditation for studies completed aboard our modern 188' barkentine are provided by West Island College, CEGEP Marie Victorin and the Quebec Ministry of Education. Class Afloat is a programme of West Island College and offers students the opportunity to live, sail and study aboard a traditionally rigged vessel while traveling to more than 35 exotic destinations around the world. If you are interested in this "passport to education" and want more information, please contact the Class Afloat office at 1-800-301-SAIL.

6. Organization of Instruction

- ***A Semestered Timetable***

Several Secondary I, II, III courses, and the entire Secondary IV and V programme are organized about a semestered timetable that operates similarly to that of a college or university. During the course of a year, students complete the same number of courses as in a non-semestered system. The year, however, is broken into two semesters. Students take the first half of their total course load during the first semester (August to January), write their final exams in January, and the second half of their course load during the second semester (February to June).

Having experienced much success in our western provinces, semestered programming is rapidly gaining popularity here in Quebec. West Island College Montreal has over two decades of semestered programming experience and therefore serves as a reference for other schools contemplating this form of scheduling. Over the years, the overwhelming majority of alumni have reported that the semestered experience, coupled with an excellent foundation in exam and project preparation, have been primary factors leading to their success in post-secondary studies.

Our semestered and fixed five day, Monday - Friday timetable also reaps curriculum benefits in that it allows far more flexibility to participate with timetables in industry and the community at large. Examples of programmes directly benefiting senior students are the Off-Campus Educational Partnership Programmes: Community Outreach, Science Practicum, Commerce Practicum, Sports Leadership Practicum, Self Designed Practicum, and the Physical Education Life Sports Programme.

7. Enriched Programme Philosophy

Junior School: Secondary I, II, III

The content of West Island College's junior school enriched programmes are quantitatively similar to those of the regular programmes, however, there are many qualitative differences. The goal is not to cover four or five more novels or throw the next level of math textbook to the child. This merely involves acceleration or "covering ground" which is not synonymous with enrichment. The essential difference between the regular and the enriched programmes is thus the depth to which literary texts and math units are studied. This approach serves the West Island College student well. It allows a student to move from regular to enriched programmes from year to year.

In English, the stronger students are not content with a literal interpretation of what is read. Unaided, the student is able to ascertain "what happened" and "who did what to

whom”. The superior student moves inexorably to the difficult questions posed by the literature: “ Why did these circumstances produce these results?” He wants to go beneath or beyond the surface texture of the work in order to grapple with the vision of reality that lies at the heart of a literary text. Hence the difference between the regular and the enriched English programme is depth.

In French, stronger students have the opportunity to study a language and literature programme. To that end, students are assigned to either Français enrichi (langue maternelle) Français régulier (langue maternelle) or French Second Language. Remediation is addressed through specialized computer assisted learning, extra help sessions and periodic regrouping for specialized instruction.

In Mathematics, stronger students are rarely content with the one solution. They want to discover other ways to seek the answer. Enrichment in Mathematics is thus achieved primarily by the depth of attack skills which the student is encouraged to apply either within the context of daily study, mathematics competitions, or additional units of study.

Senior School: Secondary IV, V

Rather than offer advanced courses to the chosen few, we offer advanced level courses to all our students. Experience and ministry examination results indicate that this approach is well suited to our students.

Requiring all our students to become involved in school life and in the broader community through programmes such as Community Outreach has aided our students to acquire the life skills required for success.

Our goal is to provide for our students a curriculum and methodology that will develop the skills required to enter, and graduate successfully from, college.

8. *Class Assignments*

Careful consideration for class assignments is undertaken based on what will be in your son’s or/and daughter’s best interest.

Identification of homeroom classes is done through a combined number and letter (i.e.: IA, IB.) These letters are simply a means to identify a secondary level and class and it should therefore be understood that there is no prestige attached to any particular class. To that end, a student may find him/herself in Secondary IB followed by 2A the following year. The majority of the student’s core curriculum is taught within these homeroom groups: A & B groups follow their core studies in French, C & D follow their core studies in English.

Class assignments to enriched or regular sections of certain language, mathematics, and science courses differs from Secondary I – V.

- **Secondary I**

Students are assigned to classes that will best satisfy their academic needs. Class assignments for Secondary I French, & English are based upon evaluations held during the first week of classes and upon the student's language proficiency profile as established by the entrance tests. Student progress is carefully monitored to ensure the continued appropriate placement of the student.

English

Students of Secondary I are assigned to either Enriched or Regular English Language Arts. Both programmes are mother-tongue calibre. Second language English (Anglais) is not offered.

Mathematics

All Secondary I students undertake our enriched mathematics programme within their homeroom groups. Our objective is to prepare all students for the enriched Secondary IV & V mathematics programmes. Please consult the "Math Programme Sequence" for further information.

Français

Students of Secondary I are assigned to either Français langue maternelle or Français Immersion programmes. Please consult the "French Programme Sequence" for further information.

- **Secondary II**

In keeping with the school's motto, "The Pursuit of Excellence", we believe it is healthy to expose students to advanced level programmes, new friends and teachers as much as possible.

To that end, Secondary I students may anticipate changing homeroom groups A-B & C-D upon entering Secondary II. The class assignments for French & English language courses remain similar to Secondary I.

- **Secondary III**

Secondary III students begin their introduction to the mature student philosophy towards enriched programmes.

Rather than offer advanced courses to the chosen few, we offer advanced level courses to all our Secondary III students. We feel that the Secondary III student is sufficiently mature to begin accepting responsibility for his/her own enrichment and thus the English programme is taught within three heterogeneous groups, all of which receive enriched programming. Students are encouraged to seek out enriching experiences on their own both inside the context of the course and outside the confines of the classroom.

In keeping with the school motto of the pursuit of excellence, the students are carefully assessed for placement in either Français Langue-Maternelle III, Français Immersion III, or French Second Language. In an attempt to encourage fluent bilingualism, all students who are capable are assigned to a mother-tongue Français III programme. French Second Language may be offered to those students for whom mother tongue programmes in Secondary I and II have proven to be too difficult a challenge and who have certificates of eligibility entitling them to English instruction. Please refer to “Matriculation” section II-4 for further information and the “French Programme Sequence”.

- **Secondary IV & V**

At West Island College, we endeavour to offer inspiring and current curricula. To that end, the senior course options available to students is updated annually and represents the reflection, and inspiration of the teachers, students, alumni, administrators, and the Board of Governors’ Curriculum Development Committee. Parents are invited annually to a Course Selection Information Session and are urged to assist the student with his/her selection.

Consistent with our enrichment philosophy, all Secondary IV students are offered enriched or advanced mathematics and science programmes. Secondary V students have the opportunity to pursue French courses consistent with their ability in Français langue maternelle V, Français Immersion V, or French Second Language. Qualifying students may pursue Enriched or Advanced Mathematics V and Pre-calculus. Furthermore, all Secondary V students pursue our Enriched English V course. Students are also encouraged to exercise maturity and pursue independent enrichment both inside the context of the course and outside the confines of the classroom.

Secondary V students are counselled, but not restricted, to select optional curricula from one of four paths that allow for a theoretical and practicum component in each of the post-secondary disciplines that the majority of our students attend at CEGEP. Each path is designed to provide for an inspiring, yet carefully guided and optional curricula; namely a theory path for students in the sciences, social sciences & commerce, or arts & languages, followed by a practicum component of an experiential nature. Each path provides a foundation for, but does not repeat, what students will undertake at the post-secondary level in similar paths. Off-Campus Practicum experiences are thereby offered to the Secondary V student during his/her final semester. The Science Careers Practicum, Commerce Practicum, Sports Leadership Practicum, Art Practicum or designing one’s own practical experience via the Self-Designed Practicum are interesting eye opening possibilities unique to the West Island College Secondary V student.

9. French Programme Sequence

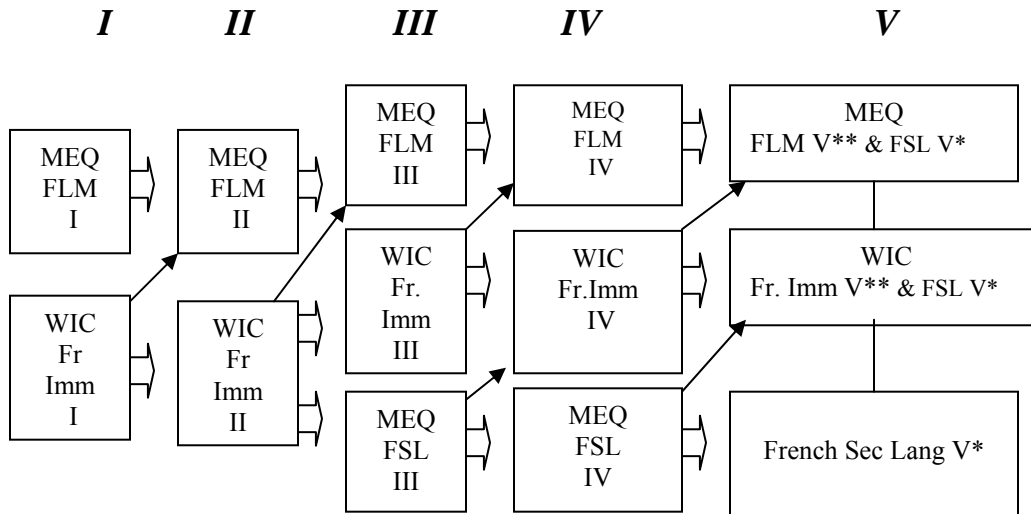

Students at West Island College undertake mother-tongue calibre French programmes in Secondary I & II. Streaming to either second language or mother tongue programmes may begin at Secondary III. In keeping with the college philosophy of the pursuit of excellence, students are encouraged to pursue programmes commensurate with their ability. Crossover to a more demanding programme of study may be considered.

* High School Leaving Second Language French (Eligibility required)

** Qualifies for WIC Certificate of Bilingualism

MEQ-FLM Ministry of Education -Français Langue Maternelle programme

MEQ-FSL Ministry of Education - French Second Language programme (Eligibility required)

WIC-Fr. Imm West Island College - Français Immersion programme (Eligibility required)

COMPULSORY FRENCH PROGRAMMES

FRANÇAIS LANGUE MATERNELLE

FRANÇAIS IMMERSION

FRENCH SECOND LANGUAGE

In keeping with the college philosophy of the pursuit of excellence, students are encouraged to pursue one of three advanced French programmes commensurate with their ability: MEQ Français Langue Maternelle, WIC Français Immersion or MEQ French Second Language.

At West Island College, we refer to mother-tongue programmes as “Français” and second language programmes as “French”. The calibre of the programme and evaluation criteria differs significantly between the programmes.

The most demanding of the three levels of study are the Français Langue Maternelle programmes (MEQ-FLM). The Ministry of Education requires the mother tongue programme MEQ-FLM V for students to graduate from a French language school. The French Second Language 594 course (MEQ-FSL 594) is the matriculation level second language programme required by the Ministry of Education for Secondary V students in English language schools. The WIC Français Immersion programmes (WIC-Fr. Imm) are locally developed WIC Français langue maternelle based courses designed to meet the language development needs of eligible* students that are not met by either of the aforementioned MEQ courses.

The primary difference between the programmes is the focus of study of the subcomponents. In MEQ mother tongue programmes, oral acquisition is assumed and thus counts for only 10% of the course. The focus is on mother tongue level reading comprehension (40%) and writing (50%). The Français Immersion programme employs similar methodology and the same textbooks as the langue maternelle programme yet seeks a more equitable distribution of the sub-components: writing (1/3), reading (1/3), and oral (1/3). In second language programmes, the emphasis is upon oral development. The second language course is equally weighted across four sub-components: writing (25%), reading (25%), listening (25%) and speaking (25%). The second language MEQ V exams are required of all eligible Secondary V students regardless of the programme of study.

In an attempt to achieve higher marks, some students question the desirability to pursue the more demanding programmes. We at West Island College recognize the increased demands placed on students whom by choice, pursue the more demanding mother tongue Français or Français, Imm. programmes. Pursuant to our motto, we seek to encourage students to strive for excellence and continue with programmes commensurate with their

ability. This is true of all disciplines. Thus the obvious answer is to acquire the best possible education commensurate with the student's ability. Nevertheless, several initiatives are taken to reward students who choose to continue with the increased demands of mother tongue Français programmes.

Why should a student attempt mother tongue calibre French courses?

- First and foremost, students in langue maternelle are expected to acquire superior French writing and reading skills. This is a very appealing attribute for future employment.
- Students who successfully complete Secondary V English and either Français langue maternelle 5e or Français Immersion V qualify for the *West Island College Certificate of Bilingualism*
- It is important to note that upon completion of either Secondary V course: Français 5e, Français Immersion V, or French V, all eligible* Secondary V students write the French Second Language V matriculation exams. This allows eligible students to satisfy their second language matriculation requirements and thus facilitates the CEGEP application process because many English CEGEPs wish to refer to the second language mark to establish acceptance. Furthermore, students can then point to their superior Français course as a value-added language credit
- Contrary to popular rumour, the academic averages that appear on school report cards are used almost exclusively for internal purposes. Since many schools calculate overall averages differently, most post-secondary institutions determine the satisfaction of admissions criteria based on the average obtained for specific courses rather than the overall average on the school report card.
- When applying to CEGEP, students who possess the *Certificate of Eligibility for English Instruction* and who have successfully completed the advanced Français programmes are provided a letter from WIC to include with their application. The letter emphasizes the virtue of having opted for the more demanding programmes. Furthermore, it alerts the CEGEP admissions officer to consider the greater percentage of either course.
- As a further incentive for students to continue with mother tongue courses, President's Honour Roll (P.H.R) consideration is given to students who are enrolled in Français Langue Maternelle programmes by choice and have demonstrated superior effort. The Headmaster may grant President's Honour Roll if and when the student's term result in Français langue maternelle would otherwise exclude them. This consideration does not apply to Français Immersion or French Second Language programmes.
- Eligible* and deserving students who do not successfully complete Français langue maternelle 5e may be granted credit for the Français Immersion programme at the discretion of the Headmaster.

- It should be noted that students who graduate with both mother tongue level Français 5e and English 516 credits are recognized as having graduated from both French and English high schools. This may be interpreted as official recognition of bilingualism and therefore superior to a “Certificate of Bilingualism” which is issued by the school and is subject to that school’s definition of bilingualism.

*Eligible is defined as students who possess a *Certificate of Eligibility for English Instruction as per the French Language Charter*

10. Math Programme Sequence

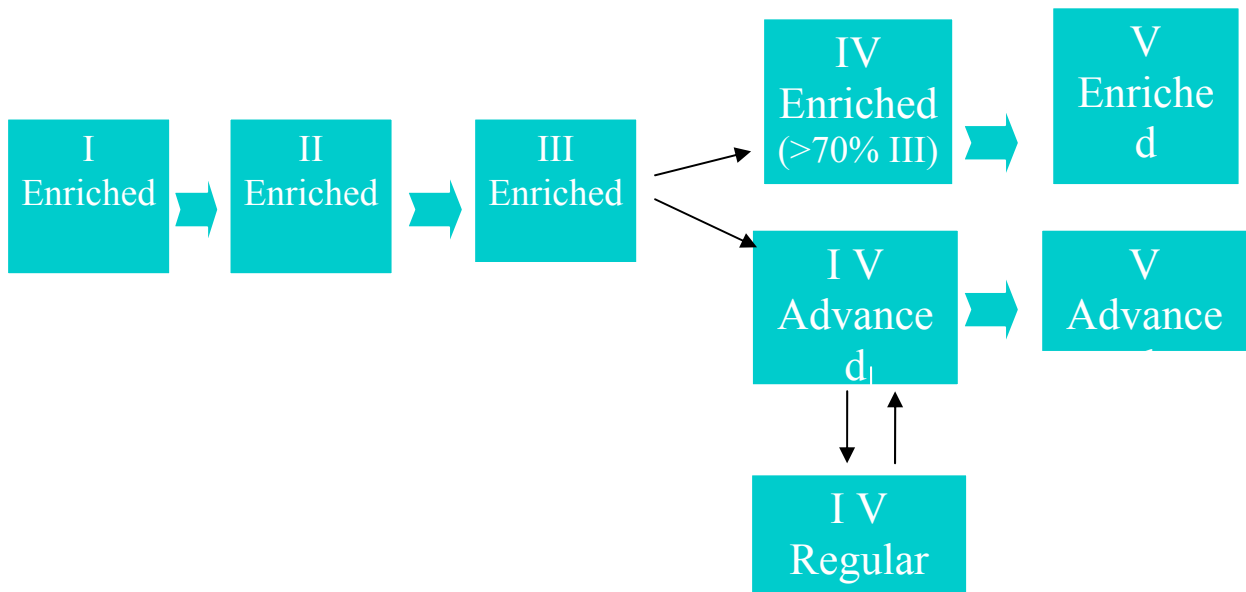

ENRICHED MATHEMATICS PROGRAMME SEQUENCE

Pursuant to the college philosophy of the pursuit of excellence, all students follow enriched mathematics courses in Secondary I, II, III. Upon entering Secondary IV, students are streamed to pursue one of two different yet advanced math courses.

Secondary IV Enriched (*Science Option*): qualifies for CEGEP studies in sciences),
 Secondary IV Advanced (*Technical and Scientific Option*): qualifies for CEGEP technical sciences and business administration) and Secondary IV Regular: (*Cultural, Social and Technical Option*): qualifies for collegial studies in the arts, communications, humanities and the social sciences).

11. English Programme Sequence

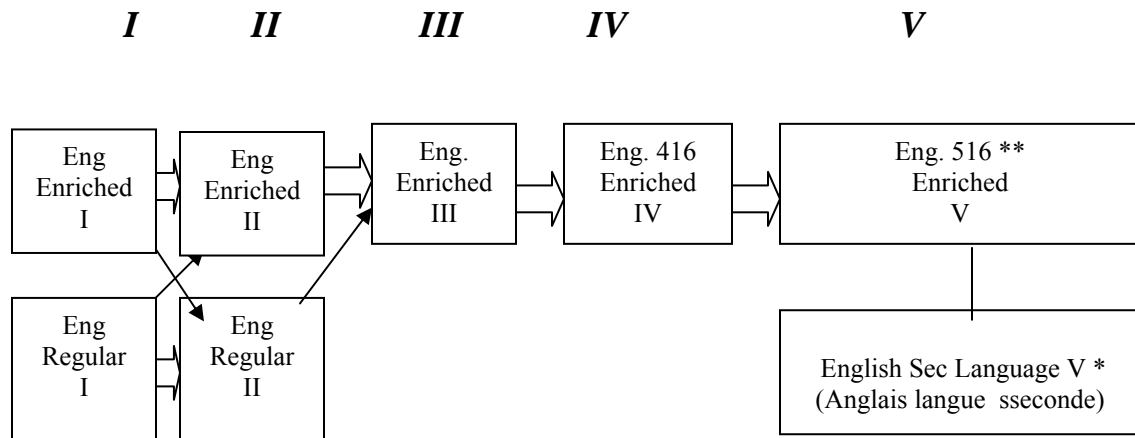

* **High School Leaving Second Language English Exam (Required of Francophones)**

** **High School Leaving Mother Tongue (Required of Anglophones)**

Students of Secondary I and II are assigned to either Enriched or Regular English Language Arts. Both programmes are mother-tongue calibre. Second language English (Anglais) is not offered.

Rather than offer advanced courses to the chosen few, we offer advanced level courses to all our Secondary III students. We feel that the Secondary III student is sufficiently mature to begin accepting responsibility for his/her own enrichment and thus the English programme is taught within three heterogeneous groups, all of which receive enriched programming. Students are encouraged to seek out enriching experiences on their own both inside the context of the course and outside the confines of the classroom.

ENGLISH 416

The English 416 programme at West Island College is an advanced mother-tongue programme. This course synthesises the analytical and linguistic skills introduced in the junior school. Formal preparation for CEGEP English programmes begins at this grade level, particularly with the acquisition of essay writing skills. In addition, the various creative writing forms are taught.

Literary emphasis is placed on the study of poetry and the short story. Drama is embraced through a study of Shakespeare. Themes such as “Utopia – Dystopia, and The Heart of Darkness” will be explored through all the genres. Ongoing through the programme is vocabulary development, independent reading and enhancement of oral skills.

ENGLISH 516

The English 516 programme at West Island College is an advanced mother-tongue programme. This programme prepares the student for the demanding challenges of CEGEP and university English courses by further developing basic skills of reading, listening, responding, thinking, speaking, and writing, with the emphasis on the various styles of writing.

The core curriculum will focus on the study of the essay and literary analysis. A Shakespearean play, public speaking skills, and several novels are an essential part of the programme. The students will explore these mediums while learning both the transactional and creative writing styles.

Please note: Students who are registered in the English sector must successfully complete this course and must write a final matriculation examination in order to graduate from high school. (See “Matriculation”.) Students who are registered in the French sector may take English Second Language V final exams in addition to the mother tongue 516 examination.

ENGLISH SECOND LANGUAGE V (ANGLAIS LANGUE SECONDE V)

West Island College students who will graduate in the French sector are required to graduate with Français langue maternelle and English Second Language. The course is not offered separately at West Island College. Rather, it is integrated to the Enriched Mother Tongue programme. West Island College students who will graduate from the French sector are required to write the Ministry final English Second Language exams above and beyond the English 516 exam. This typically serves as a solid credit to demonstrate to French Post Secondary Colleges and Universities.

III - Student Life

1. Student Groups

- **The House System**

Upon entering West Island College, every student becomes a member of a House, and thus, is immediately part of a family within the family of the school. The Houses are made up of students from Secondary I to Secondary V and each has approximately the same population as the other.

Each House has been named to honour individuals who have had a direct impact on the school.

The Houses are: Davies House
 Grant House
 Martin House

Staff advisors are assigned to each House. They act as animators for the discussion of student issues, help in supporting student and school initiatives and can be a sounding board for student concerns.

House Captains are selected by the administration for each of the Houses. This senior student is selected for his/her enthusiasm and positive attitude, and leads their respective Houses in the pursuit of the annual House Championship (Morgan Trophy). Through House elections, members of each House elect their own House level representatives who sit on the House Council.

- **Assemblies**

West Island College is a community. In order to underscore the importance of a sense of community, the College's population meets, as a group, several times a week. This assembly, led by the Head Girl and Head Boy, focuses on the celebration of the various achievements or efforts of members of the school community. In addition, announcements pertaining to school events are made.

- **The Green and Grey Society**

The Green and Grey, is in part, elected by students and in part selected by staff. It provides, for the school, a variety of student leadership opportunities and is managed by the Head Boy and the Head Girl, who are chosen by the Faculty.

The Members are: The Head Boy and Head Girl
 The House Captains (Junior and Senior)
 The President and Vice President of the House Council
 The President of W.I.C.A.A.
 The Grad Committee
 The Yearbook Editors
 The Interact Executive

The criteria for these positions are conformity to school rules, uniform and dress code as outlined in the Handbook, maintaining an average of 75% or better in the core courses, and participation in at least two school activities during the course of the past year. Its members are the College's official hosts and hostesses. The Green and Grey's role is to represent and to serve the school community.

• **House Council**

An important voice for the students at W.I.C. is the House Council or student government. Prior to the beginning of the school year, Junior and Senior House Captains are selected to represent the students in the House Council. As well, a school wide election takes place to choose a student President and Vice President to lead the House Council.

The council is the students' voice in the school. Its mandate includes, but is not restricted to:

- Student advocacy
- Organization of school spirit activities
- Charitable work

• **West Island College Athletic Association (W.I.C.A.A.)**

W.I.C.A.A. is responsible for all athletic events in the school. The association organizes the Intra-mural programme, trains and schedules timers and scorers for interscholastic competition, organizes the athletic awards, and calculates the individual and House points as they are earned.

2. House Championship

Over the course of the year, the three Houses compete against each other for the House Championship or Morgan Trophy. Points are awarded to each House for both academic and non-academic activities and for both individual and team participation.

Academic Points

- | | | | |
|----|-----------------------------|---|---------------------|
| 1. | Headmaster's List | = | 10 points / student |
| 2. | President's Honor Roll | = | 10 points / student |
| 3. | Highest Average per grade | = | 5 points / student |
| 4. | Top Junior / Senior Student | = | 5 points / student |

Non Academic Points

Individual Points

- | | | | |
|----|------------------------------|---|----------------|
| 1. | School Team Member | = | 10 points |
| 2. | Club member | = | 5 points |
| 3. | Participation in intramurals | = | 1 point / game |

Team Points (House League)

- | | | | |
|----|-------|---|----------------|
| 1. | Daily | - | win = 5 points |
| | | - | tie = 3 points |
| | | - | loss = 1 point |

2. League Standings
- First = 25 points
 - Second = 15 points
 - Third = 10 points
 - other = 5 points

** Other points to be awarded at the discretion of the coordinator (i.e. Spirit Days, etc.)
 These points are posted at the end of each term.
 The Morgan Trophy is awarded to the winning House at the end of each school year.

3. *Extra Curricular Activities*

Every student is encouraged to participate in extra curricular activities, with the goal being that the students develop leadership, commitment to tasks, and a strong sense of belonging to the school community.

● Clubs

A variety of student clubs operate in the College with meetings generally taking place at lunchtime. While some clubs are fixtures on the College's calendar, others are created as student interests and teacher interests find a marriage.

Following is a complete list of all of the extra curricular activities for the 2007-2008 school year, as well as the staff advisor involved.

Art Club	V. Caldareri
Ceramics	V. Vien
Debating Team	T Berger, T. Grivas
School newspaper	M. Msika, M. Pitcher
Golf Club	T. Duchene
Grad Committee	G. Baraby
Green & Grey	Administration
House Council	R. Reid
House League	WICAA
Jr. Jazz Band	B. Bowles
Muscle Toning	D. Bambic
Peer Tutoring	K. Wolfe
Robotics	P. Nantel
Service Club	C. Segal
Ski Club	B. Bowles
Interact	J. Henderson
Table Tennis Club	E. Nadar
Theatre	F. Myers
Variety Show	C. Buzaglo

4. Inter Scholastic Sports Programme

The College competes in the Greater Montreal Athletic Association and the Montreal Independent Schools Association leagues in a number of sports.

• Policies & Procedures

◆ Pursuit of Excellence: Academic and Athletic

Students who participate in interscholastic sports are not only required to fully participate on their teams, but also to continue to strive for their highest possible academic standing. This achievement takes planning and time management on behalf of the student so that all required work is completed on time. Players are expected to meet the commitments of the classroom, as well as the School team including practices, games and tournaments. Should a player not be able to participate in a particular activity, the coach should be advised in advance.

◆ Interscholastic Sports Participation Policy

Students who are capable of competing on an interscholastic sports team are strongly encouraged to do so. They may play for both the School and their community team provided that:

- * in the event of a conflict, the School game is given first priority.
- * the student's academic standards are maintained.

In committing to the School team, the student agrees to attend all practices, exhibition and league games, playoff games, and tournaments. If a conflict arises between a school practice or exhibition game, and a community game, the student may be excused at the discretion of his/her coach.

A student who is in breach of this policy may not receive their ECA credit, and risks being removed from that school team. Any future participation on school teams on the part of the student would be subject to the approval of the Director of Student Services.

◆ Academic Difficulty

Students who are in academic difficulty or who are not working to the best of their ability may be suspended from their team by the Headmaster. They may later be reinstated if the difficulties are resolved.

◆ Player Conduct

Student athletes are highly visible ambassadors for the school; as such they are expected to act accordingly **at all times**. Students, whose conduct is deemed unacceptable, either on or off the court, may be suspended from their team by the Director of Student Services. Sportsmanship, proper language and courtesy are the criteria applied to the meaning of "acceptable".

◆ Transportation

The school will provide transportation for most league competition. Students wishing to leave the team from the site of an away competition must submit a permission slip, signed by a guardian, before leaving WIC for the competition. It is hoped that all parents of players will make an attempt to come to see their children participate.

◆ **Early Dismissals**

Students are responsible for any work missed due to early dismissals. Therefore, students must see their teachers before the event. They are to hand in any assignments which are due and will be informed of what is being covered in that class.

◆ **Uniforms**

Team uniforms are provided by the school for all team members. These uniforms are only to be used for competition. Students will be responsible for the replacement cost of any lost, stolen or damaged uniform.

◆ **Water Bottles**

All members of School teams are encouraged to have their own water bottles for athletic competition. For health reasons, the school has discontinued the practice of having a team set of water bottles for games.

◆ **Showers**

All students are encouraged to take showers after games, practices and Physical Education classes.

◆ **Tryouts, Practices and Game Schedules**

Practice schedules and game schedules are given to the players after the team is selected. Tryouts are advertised in the daily announcements or the Au Courant, the school newsletter. Practice times fall into one of the following slots:

06:30 - 07:45

15:15 - 16:30

16:40 - 17:55

Generally speaking, junior teams are given priority for the 15:15 practice time slot.

• **Coaching Staff for 2007 - 2008**

Basketball	Bantam Boys	G. Neill
	Bantam Girls	B. Maks
	Midget Boys	R. Reid
	Midget Girls	J. Neill
	Senior Girls	S. Johnson
	Senior Boys	R. Reid
Cross Country Running	All categories	V. Vien
Golf	Open	T. Duchene
Halo Run	Open	P.E. Department

Rugby	Bantam Boys	M. Bailly E. Simard
	Senior Boys	G. Neill J. Thompson
Soccer	Bantam Boys	C. Leone
	Bantam Girls	S. Johnson
	Senior Boys	P. Nantel
	Senior Girls	M. Al Hilli
Swimming	All categories	F. Myers
Table Tennis	All categories	E. Nader
Touch Football	Senior Boys	C. Brais B. Maks
	Bantam Girls	B. Maks
	Midget Girls	C. Brais
	Senior Girls	R. Reid
	Track & Field	All categories

- **Age Categories for 2008-2009**

<i>Basketball</i>	<i>Bantam Girls</i>	<i>All Secondary I and II, or Bantam age girls.</i>
<i>Soccer</i>	<i>Bantam Girls</i>	<i>All Secondary I and II or Bantam age girls.</i>
<i>All other sports</i>	<i>Bantam</i>	<i>Born Oct. 1st, 1994-Sept. 30,1996</i>
	<i>Midget</i>	<i>Born Oct. 1st,1992-Sept.30, 1994</i>
	<i>Juvenile</i>	<i>Born in 1990, 91, 92</i>

- **Fall Season Team Tryouts**

The fall season includes teams in Soccer, Touch Football, Volleyball, Cross Country Running and Golf. Interested students will find more information concerning sign-ups and tryouts on the Interscholastic bulletin board outside the gym, and at school assembly.

For more information, please see Mr. Reid.

5. *House League*

With goals of friendly competition and participation, House League is open to all students, and is conducted weekdays during the lunch hour. The games are conducted between players of the same grade levels and allow students to accumulate points towards individual athletic awards and the House Championship. Sign-ups take place during the Phys-ed period or on the House League bulletin board.

Games are advertised on the W.I.C.A.A. Board and at the daily assembly. “Open Gym” days and Special Events (e.g. Staff vs. Students) are also scheduled during the lunch hours.

6. Leadership Camp

Designed to build team spirit and enhance students’ skills to lead and to contribute to their community, the camp involves a series of workshops, and team building exercises, as well as opportunities to begin the planning, and organizing of a wide variety of activities in and around the school. The two-day retreat takes place in August, prior to the beginning of the school year. All students who are members of Green and Grey, House Council, WICAA, Grad Committee, and Yearbook committee are required to attend.

7. Orientation for New Students

Perhaps the most trying time during a student’s career at school is the first few days as he/she attempts to learn new rules, new systems and become comfortable in a new environment. To help in this transition, the Department of Student Services organizes a variety of events and services for all of the new students; it is specifically aimed at making the first few days as informative and welcoming as possible.

- **Welcome Week**

All students are welcomed back for the new school year with a variety of events, which are not only fun, but also informative. A BBQ on the first day, inter House competitions, and staff-student challenges are among the planned activities.

- **New Student Orientation**

All Secondary I students spend an entire day in a school orientation program. During this time, they learn about school structures and programs, meet student leaders, as well as staff, and tour the school. At the end of the day, students have their first opportunity to earn points for their House when they take a fun quiz to see how much they have retained from the session. New students from levels II-V are given a similar initiation during the first week.

IV - Awards & Ceremonies

1. Awards

- **Headmaster's List**

The Headmaster's List is awarded for the term according to the criteria published on the report card.

- Performance commensurate with ability. Effort grade average not to exceed 1.8

- Satisfactory performance in all areas of citizenship.
- At least one extra-curricular activity per term.

Students who have qualified during two or more terms are recognized at our Opening Honour's Ceremony and their names are entered on the College's Permanent Honour Roll.

- **President's Honour Roll**

The President's Honour Roll is awarded for the term and *annually* to all students who achieve an academic average equal or superior to 85%.

Qualifying students are recognized at our Opening Honours Ceremony and their names are entered on the College's Permanent Honour Roll.

- **Honours Society**

Students qualifying on both the *annual* Headmaster's List and President's Honour Roll join the ranks of the Honours Society for the subsequent academic year.

Honours Society members are recognized at our Opening Honour's Ceremony as recipients of the Honours' Society tie.

- **Merit Awards**

Each teacher at West Island College may grant an award of merit to a deserving individual from each of the classes he or she teaches. The criteria for the award, determined by the teacher, recognizes the criteria set by the teacher. The Award may be granted each term and a final recipient for the year is recognized at the annual closing ceremonies.

- **Prix d'excellence**

Students who receive the highest percentage in a given course are recognized with a distinguishing lapel pin, "*Le prix d'excellence*". This prize is awarded at the annual Opening Ceremonies.

- **Ties**

Students at West Island College wear a variety of ties, each tie recognizes student achievement in programmes of study, leadership functions, and athletics.

West Island College ties are on display in the auditorium's trophy case. They are: Junior School Tie, Senior School Tie, Green and Grey Tie, House Council Tie, Honours' Society Tie, Head Boy & Girl Tie, and the Alumni Tie.

- **Scholarships**

An annual scholarship of three hundred dollars tuition is awarded to the student who obtains the

highest academic average at each grade level, Secondary I through IV. Graduating students may qualify for various scholarships leading to post-secondary studies.

- **Athletic Awards (These awards are presented at the annual Sports Banquet)**

- * ***Team Awards***

Individual awards to recognize individual achievements or qualities of athletes involved in interscholastic sports; selected by either the players or the coach of that particular team.

- * ***Most Valuable Player***

Player who has contributed the most to the success of the team; be it through skills, effort, spirit, or sportsmanship.

- * ***Most Improved Player***

The player who has shown the most improvement over the season.

- Rookie of the Year***

The best of all the first year players at that level.

- * ***Outstanding Athlete***

Awarded to a junior male and female, as well as a senior male and female athlete who meet the following criteria :

- advanced athletic ability
- positive attitude
- participation in I/S sports in all three seasons
- a strong work ethic or self discipline
- demonstrates good sportsmanship

- * ***Sportsmanship Award***

Awarded to junior and senior male and female athletes who demonstrate the following qualities :

- plays by the rules
- never quit
- never lose self-control
- behaviour should bring honour to the school, win or lose
- be courteous to others - officials, coaches, teammates, opponents, or spectators

- * ***The Golden Sneaker***

Presented to those individuals who have given a special effort to the Physical Education programme at West Island College.

ex. coaches, WICAA, staff

* ***The Athletic Guild***

Awarded to those senior students who have:

1. Participated in interscholastic sports throughout their WIC career
2. Demonstrated good sportsmanship
3. Demonstrated a positive attitude and work ethic in athletics

* ***The Outstanding Junior Student-Athlete of the Year***

This award is given annually to the junior school student who best combines athletic accomplishment with academic performance.

2. Convocation Plaques, Scholarships, Awards

These distinctions are awarded each year to graduating students at the Convocation Ceremonies.

- ***The T. Barontseff Shield***

Donated in memory of his mother by Mr. Alexis Barontseff, a former Director of Athletics at West Island College, this award is given annually to the graduating student who has achieved the highest proficiency in the study of La Littérature Française.

- ***The Board of Governors' Shield***

In order to underscore the importance which the acquisition of French language skills plays in the College's mission, this award recognizes the graduating student who has displayed the most improvement in French during the time spent at West Island College.

- ***The Brenhouse Shield***

The Brenhouse family, in memory of their late sons Philip (Class of 1982) and Lorne (Class of 1984), presents this award each year to the graduating student who is:

1. Positive and optimistic
2. Naturally generous and considerate of others' needs
3. Responsive to the group, rather than to a personal agenda

- ***The Davies Family Shield***

Donated by the father of the College's founder and President, this award is given annually to the graduating student who has achieved the highest combined score in the high school leaving sciences.

- ***The Montreal Board of Trade Award***

The Montreal Board of Trade Award is given to a graduating student who has been selected to represent West Island College as a FINALIST in the board of trade competitions.

- ***The Alexander Doucas Shield***

With the blessing of the Doucas family, the Class of 1981 donated this shield to the College in memory of their classmate, the late Alexander Doucas.

The award is presented annually to the graduating student who, as an athlete, displayed:

1. Character and integrity
2. A determination to win, achieving to the best of his/her ability
3. Respect for opponents and for all individuals with whom he/she comes in contact.

- ***The A.J. Grant Shield***

Donated by Mrs. Grant senior, this award is presented annually to the graduating student who has achieved the highest mark in English at the Secondary V level.

- ***The Melvyn Hamilton Shield***

Donated by the Hamilton family, this award is given annually to the graduating student who best combines athletic accomplishment with academic performance.

- ***The Miller Family Shield***

The Miller family, wishing to recognize the graduating student who has contributed most to the physical environment of the College through active intervention, donated this award and asked that it be presented annually.

- ***The Y.M.C.A. Community Service Shield***

The Y.M.C.A. Shield is awarded annually to the graduating student who has demonstrated a commitment to the community through volunteer service.

- ***The Erlick Family Shield***

This award is presented to the boy or girl who has maintained an above average academic standing combined with: demonstrated leadership skills, sensitivity to ethnic and cultural diversity and, a strong commitment to volunteerism.

- ***The Kay Family Scholarship***

Donated by the Kay Family, Katherine (Class of 1979), Patricia (Class of 1983), and Sean (Class of 1988), this \$500.00 Scholarship is awarded annually to a deserving graduating student who studies in a social science field at the University level having successfully completed a D.E.C.

- ***The Muriel Davies Head Boy and Head Girl Award***

Presented in memory of the late Mrs. Muriel Davies, mother of our Founder and Honorary Chancellor, Mr. Terry Davies, this award is presented to the Head Boy and Head Girl of the College as recognition of their extraordinary leadership and service to their school.

- ***The Eakeley Shield***

The Eakeley shield is awarded annually to a Senior student who places first in the College's public speaking competition.

- ***The Royal Bank of Canada Shield***

This award is presented annually to the graduating student who has the combination of the highest mark in Secondary V Mathematics and the best performance in the Mathematics' Competitions entered by the College.

- ***The West Island College Editors in Chief 'Voyages' Shield***

This award is presented annually to the Yearbook editors.

- ***The McGill Science Award***

This award is being offered by McGill University to a graduating student who shows exceptional promise in Science and Mathematics. McGill will provide a \$300 book credit redeemable if the student eventually registers at McGill University.

- ***The Lakeshore Rotary Club Interactor of the Year Award***

This award is presented annually to the graduating student or students who as a member of the West Island College Rotary Interact Club best personified the Rotary International motto of 'Service Above Self'.

- ***The Lieutenant Governor's Award***

This award is presented to a graduating student to recognize his/her merits, not only in academic achievements, but also in the level of personal, social and community commitment.

- ***The Governor General's Academic Medal & The West Island College Outstanding Academic Achievement Shield***

This combination of awards is presented to the student who has achieved the highest academic standing in the graduating class.

3. Ceremonies

Implicit in West Island College's mission is a partnership which calls upon each of the partners to make some special efforts. As we ask more of our students inside and outside of the

classroom, so must we also recognize, formally, the substance of their many accomplishments. Essentially, there are three moments each year when we pause to celebrate the extraordinary achievements that are synonymous with a West Island College education. They are: ***The Opening Ceremonies, The Closing Ceremonies and the Graduation Ceremonies.***

During “***Opening Ceremonies***”, held in early September each year, we assemble the entire student body and our parents in order to recognize those students, who, the previous year, achieved outstanding academic results. To celebrate leadership achievement, we assemble, in June, the entire student body and their parents for “***Closing Ceremonies***” in order to recognize those students who excelled academically or whom were involved in one or more of the myriad of the College’s extra-curricular activities. The third celebration, “***Graduation Ceremonies***” is an event exclusively reserved for our graduates and their families. It is held in June following the examinations.

V - Evaluation & Communication

1. Evaluation

• **Philosophy**

The College's philosophy of evaluation incorporated two very distinct purposes of measurement: summative and formative.

Summative evaluations are intended to measure for purposes of reporting and measuring course mastery, student progress. The results of these evaluations appear on report cards. Formative evaluations serve as learning and teaching tools, and, as such they may form an integral part of the teacher's lesson plan. Their purpose is threefold:

1. To assess student acquisition of learning objectives;
2. To direct need for remediation or enrichment;
3. To assist in planning for re-teaching.

• **Report Cards**

* **Report Cards Intent**

The intent of the report card is to inform students and parents of progress in a course and to measure that progress in relation to each student's potential. To that end, students are accorded a progress report and a competency development and/or anecdotal report each term. Sample progress reports follow.

◇ **Format**

The report card consists of two parts: a Progress Report and a Anecdotal Report or Competency Development Report.

The progress report indicates the student's record as tabulated for each term. It is an overall record of academic results recorded as percentages and an effort evaluation for the period of time indicated. Citizenship evaluation, extra-curricular participation, absences to class and recognition for the Headmaster's List and President's Honour Roll are also recorded. A print-out of the progress report is given to each student. The print-out may be kept for your records. It is not necessary to return a signed copy. Students must return a signed report card receipt.

Students receive a Competency Development Report and/or Anecdotal Report depending on the grade level. Either report appears as complementary pages to the progress report. Each subject specific competency is rated and the teacher provides a written comment.

* **Report Card Interpretation**

◇ **Semester or Term?**

Report cards are issued four times per year (twice per semester). Many of W.I.C.'s courses, particularly in Secondary IV and V, are semestered. This implies that they are taught with double frequency for half the year and are completed at mid-year. See "Organization of Instruction" for more information.

The year is divided into four terms, to wit:

Semester I, Term 1
Semester I, Term 2
Semester II, Term 3
Semester II, Term 4

◇ **Course Evaluation Section**

All courses at West Island College receive a percentage and effort evaluation. The frequency of evaluations is dependent upon the frequency with which the course is taught. Courses meeting a minimum of three days a week receive a percentage and effort evaluation each term. Some courses, particularly those taught twice a week or less, may not be reported each term. In this case, marks are accumulated and reported when they represent an accurate assessment of the student's results.

◇ **Calculation of the Final Grade (mark)**

The calculation of a final mark in a course may vary from course to course and from department to department. At the beginning of each year/semester, teachers issue a complete course description detailing to each student not only the course content but also the method that will be used to generate a final grade.

Sec. IV & V Courses

Unless otherwise indicated upon the student anecdotal report, the mark which appears in the "Summary Column" is consistent with MEQ standards such that the course work is 50% and the final exam is 50%. To wit:

Term 1 or 3	25%
Term 2 or 4	25%
Final Exam	<u>50%</u>
TOTAL	100%*

It is important to note that the summary mark which appears on the WIC report card is not the final mark which will appear upon the student's government issued transcript if the course is subject to a MELS (Ministère de l'Éducation, du Loisir et du Sport) matriculation final exam. In the case of a MELS examined course, the "school mark" will be combined with the final MELS examination mark and this combined mark will appear

on the government transcript. This transcript will be sent directly to the student by the Government of Québec. It is the mark which appears on the Ministry of Education transcript that determines whether or not a student receives credit for a course.

*** Effort Rating**

Effort is a criterion based assessment which is given careful consideration by all teachers. The ranking is on a scale of 1 to 5 indicating the effort the student has invested in the learning process. The key is printed on the report card.

In arriving at an effort grade, the teacher assesses the following criteria.

- Punctual submission of work
- Attention in class
- Participation in class
- Completion of homework
- Attempt to produce quality work
- Preparation for class

*** Effort Grade Average**

All courses receiving an effort evaluation count equally towards a non-weighted average which is printed on the report card next to the academic average. It is this average which partially determines qualification to the Headmaster’s List. See Awards & Ceremonies for criteria.

◇ **Academic Average Calculation**

Most courses count towards the academic average. The average is weighted and calculated automatically by computer such that the weight assigned to a course reflects the credit value and the time attributed to instruction. The weight assigned appears on a scale from 0 to 6 in the Course Evaluation section under the column labelled “W”.

SAMPLE CALCULATION: Academic Average

	%		Weight	=	Total
Ed. Physique	82	x	2	=	164
Informatique	81	x	1	=	81
Science	85	x	4	=	340
Math	78	x	6	=	468
Ed. Morale	80	x	1	=	80
Histoire	91	x	4	=	364
Français	86	x	6	=	516
Arts Plastiques	81	x	2	=	162
English	82	x	<u>6</u>	=	<u>492</u>
	TOTAL		32		2667

Average: $2667 \div 32 = 83.34$
 Average rounded = 83%

*** Citizenship Evaluation**

Citizenship is evaluated as per the criteria indicated upon the report.

To recognize community service, an "S" denoting satisfactory, is entered for those students who have participated in an extra-curricular activity during the term or have otherwise demonstrated an extraordinary contribution to the school community. The "S" is recorded within the citizenship category "Contribution to the School Community".

2. Communication

At West Island College we often speak of the communication triad which must exist between student, teacher and parent. In order to be effective educators and a true "community of learners", we must be a functioning team. To that end several communication tools exist in order to facilitate communication. They are:

- **Newsletters, Notices & Website**

Our newsletter, *Au Courant*, is published regularly each year and is typically mailed or sent along with report cards. A weekly electronic version, *Au Courant - On Line* is issued each Friday. All parents and students are encouraged to be on-line. *Au Courant* is one of our primary means of communication and thus all students and parents are requested to read it carefully. Notices of upcoming events, areas of concern, changes, as well as some thought provoking editorials are published in the *Au Courant*.

Throughout the year, memoranda are also issued to students and parents. The memorandums are issued via email and/or hard copy. Unfortunately, sometimes the student does not deliver the paper based versions of the memos to the parent. Please establish a routine at home to encourage the delivery of these notices.

- **Report Cards**

As described in the "evaluation" section, the report card includes two components. It is a progress report and equally important it is anecdotal (Composed of written comments).

- **Carnet de l'élève**

The carnet de l'élève is a brief memo to the student and parent bringing focus to exemplary achievement, social progress or disciplinary action. It may be used to supplement the report card anecdotal comment. All carnets should be signed by both the parent and student to acknowledge receipt and returned to the sender or the detention hall supervisor.

- **Agenda Signing**

Parents of Secondary I are asked to sign the student's agenda on a daily basis for a period of time during the student's first year. It should be noted that this signing is requested to encourage the proper usage of the agenda tool by students. This skill is taught in the Secondary I Study Skills course and the parent is advised of the method that is encouraged. The content of what the student has inscribed for homework assignments is neither necessarily accurate nor verified by each teacher on a daily basis. However, if a student has

difficulty completing homework obligations, the student's administrator may initiate a compulsory agenda signing or tracking programme.

- **Telephone: Who to Call**

Should you have a concern that is specific to your child's progress in one class or another, we encourage you to speak directly with your child's teacher. If, after having spoken with the teacher, you prefer to speak with an administrator or guidance counsellor, please do not hesitate. We believe in the triad of communication. If you are not sure to whom to direct the call, please refer to section I-7 School Administration, or section I-8: Personnel, or the College Receptionist at 514-683-4660.

- **Telephone Availability: Students**

Students may not use the school telephones except for emergencies. Public telephones are available for students.

- **Parent Information Evenings**

Several important Parent Information Evenings are hosted throughout the year. Attendance is highly recommended. These evenings are announced by memorandum, in the Au Courant. Parent Information Evenings which are hosted annually are: West Island College Inc.'s Annual General Meeting, Orientation Evening for Parents New to W.I.C., Parent Teacher Interviews (Fall & Spring), Senior Course Selection Information Evenings and Outdoor Education Information Evenings.

- **Parent-Teacher Interviews**

A most important vehicle of communication is the parent teacher interview. Typically, these interviews are very well attended at West Island College. Students may also attend interviews if the parent so chooses or the teacher requests his/her attendance. If in attendance, the student is expected to be in uniform.

- **Change of Address and Telephone Number**

Please advise the college receptionist of changes of address and telephone numbers as they occur. It is vital that we know how to reach parents in an emergency. The report card should always indicate the current information which is in our data base. If it is inaccurate, please advise us.

- **Electronic Mail**

West Island College may also be reached by E-Mail at office@westislandcollege.qc.ca

- **Internet Web Page**

You may wish to visit the West Island College Web Page on the Internet. The page can be viewed at www.westislandcollege.qc.ca. Our web page is also linked to Class Afloat's at www.classafloat.com.

- **On-Line Marks Consultation**

Students and parents may consult marks data via the West Island College portal. A confidential user name and password is provided to the user.

VI - Rules, Policies, Sanctions

1. Foundations for Success at School: Expectations, Obligations, and Responsibilities

If a student's experience at school is to be fulfilling, it presumes that the learning environment is safe and predictable, that its teachers are attentive to its students' needs and that students are constantly stimulated, exploring their own creativity and leadership potential through a variety of well designed activities. To achieve these outcomes, a good school defines, through rules and sanctions, the environmental envelope within which students work and grow. This environmental premise is a foundation to a successful learning experience at school.

At West Island College we are confident that the totality of our expectations supports a successful school experience for our students. We would be remiss were we not to enlist our parents' support for and ensure the consistent application of those expectations. Rules and sanctions are not repressive and coercive thorns, they are, rather, the framework for the civil and safe sharing of time and space. Cooperation and creative activity are, always, best supported within a safe and caring environment.

It goes without saying that West Island College's rules are a true reflection of the College's mission. We are preparing our young people for the challenges of tomorrow's world all the while insisting upon commitment to important social, moral and civic responsibilities. School rules are not totalitarian concoctions nor are they whimsical experiments in social order. They are, above all, dedicated to preserving safe, courteous and predictable behavior in the learning environment. They are not designed to inhibit the constituents but, rather, allow them the freedom to act and to exercise their motivation while remaining respectful of the time and space of others.

We share Mr. Grant's (Headmaster-West Island College, Calgary) opinion that both our schools and school systems err by not encouraging adolescents to accept a greater ownership of and responsibility for their learning. The real world demands that level of responsibility, why shouldn't schools teach it? If teenagers are irresponsible, then they are likely not asked to be accountable at home. Shouldn't they be? Dr. Carol Yellin, psychologist with the Scarborough Board of Education, makes the following observation in *Home and School Magazine*:

"I don't think kids are different today than when we were growing up, but the environment is a lot freer. Parents don't set enough limits, whether it's because they are too busy, or afraid, or because they're trying too hard to be a friend rather than a parent."

While the standards at West Island College are high and demanding, they are clear, they are thorough and they encourage our students to behave as responsible citizens.

West Island College's rules are drafted by the administration, then reviewed and approved by the Board on an annual basis. By publishing the rules, as sanctioned at the November meeting of the Board of Governors, we hope to underscore the significance we attach to the school environment. We want our students, parents and teachers to dialogue about the significance of respect, responsibility and social order. Ultimately, we want parents to support those values which characterize West Island College, are reflected in its rules and are, therefore, part and parcel of the school you chose for your children. Through dialogue with your children and their teachers we can achieve an effective community of learners and leaders. Please join the school in a partnership which can only allow us to be more effective. Please support the fair and consistent application of the school rules. We are convinced that our (yours and ours) unrelenting partnership in the quest for being the best we can be will ensure our success. Moreover, we are confident that our expectations are realistic and achievable. Should you wish to discuss the rules and their related sanctions, please don't hesitate to call the Headmaster or, should you prefer, to write to the Chairperson, Standards and Practices Committee.

In closing, we express hope that our school rules fully meet their objectives and through their careful and considered application that we will be true to our motto "praestantium consectemur", the pursuit of excellence.

2. West Island College School Rules

The philosophy underlying all school rules is:

- That all members of the school community have the right to enjoy a safe, healthy and predictable environment
- That all students will respect the rights and property of others.
- That all students who participate in school programs will do so to the best of their abilities.
- That all students will behave in a thoughtful, respectful and courteous manner while in school, in a school chartered vehicle or in attendance at a school-related function.

Students are expected to adhere to the following:

- All students will arrive to and depart from school in the school uniform and wear the school uniform at all times during the school day.
- All students will complete their homework and projects by the due date.
- All students will speak French in classrooms where a subject is being taught in French and will make every effort to respect the use of the French language.
- All students must eat lunch in school unless permission not to do so is requested in writing by parents. Students may not leave the school grounds during the lunch hour, unless their program of studies allows it.
- All students must ensure that their appearance is neat and tidy. Unconventional adornments to the body and / or uniform are not acceptable unless they are part of an approved school function.

Students are expected to refrain from the following:

- Smoking (at all times during the school day, including lunch and before and after school) in the school, on the school grounds, near the school or during activities organized by the school.
- Chewing gum in school.
- Eating in areas other than those designated.
- Using bicycles, mopeds or cars during the school day (other than at the start or end of the school day).
- Wearing in-line skates, cleats inside the school building.
- Entering the gymnasium or locker room unless attending class or having permission from a member of staff.
- Being tardy for class, house meetings or assembly.
- Leaving lockers unsupervised and unlocked.
- Use, sale, distribution or possession of alcohol or illegal substances.
- Being involved in a flagrantly immoral or distasteful act.
- Directing abusive language towards members of the school community.
- Using cell phones, pagers or other similar electronic devices in class. This rule also applies to any examination facility. Students are encouraged to leave these devices in their lockers. Any inappropriate use of these devices will result in automatic confiscation and can result in a zero mark if it is during an examination.

3. West Island College Sanctions

It is understood that each student must conduct him/herself in a civilized manner. It is clear, therefore, that infractions of this code must be pointed out to the offending students so that behavior modification may be achieved.

Each breach of the school rules carries with it a degree of gravity. As a consequence, the sanctions for each must be of varying severity.

Any behavior not considered herein which may be deemed to be in clear contravention of the philosophy underlining the school rules may be subject to sanction according to the discretion of the Headmaster.

A. Warnings shall be given for:

- Disregarding a teacher's directives.
- Neglecting to return documents when requested to do so.
- Leaving a locker unlocked and unattended.
- Uniform violations.

A warning may be verbal or written on a "carnet disciplinaire".

B. Reprimands may be given for:

- Uniform violations.
- Being late for class.
- Chewing gum.
- Eating in areas other than those designated
- Not respecting the French environment of the class.
- Using inappropriate language.
- Inappropriate behavior during assemblies.

A reprimand consists of a noon hour detention. Furthermore, an accumulation of reprimands could result in the student attending an extended detention or suspension. The student could also be placed on probationary status.

C. Detentions may be given for:

- The use of profane, abusive, discourteous or insulting language.
- Inappropriate treatment of school property or property of others.
- An accumulation of reprimands.
- Copying homework.
- Disregarding a staff member's warning.
- Being consistently late for school (first period).
- Inappropriate use of technology.
- Harassment.
- Threats.
- Defamatory libel.

A detention consists of approximately two hours of reading, writing or work sessions on Friday afternoon. Two detentions during a term will prevent a student from qualifying for the Headmaster's List as that individual will receive an "N"(needs improvement) in the citizenship evaluation section of the report card. Furthermore, an accumulation of detentions could result in the student attending an extended detention or suspension. The student could also be placed on probationary status.

D. Suspension from school may apply to the following cases:

- Cheating/plagiarism.
- Skipping class or school.
- An accumulation of Detentions.
- Fighting, intimidation.
- Defacing school property or the property of others.
- Inappropriate behavior, attitude and/or effort.
- Smoking.
- Inappropriate use of technology.
- Harassment.
- Threats.
- Defamatory libel.

A suspension can be assigned to be in-school or out-of-school. In-school suspensions usually take place on professional or vacation days and/or Saturdays. Out-of-school suspensions are used only in cases when the administration considers that it would be ill advised to allow the student to be present in school until the issue is resolved.

E. Expulsion from school may be affected in the following cases:

- An accumulation of suspensions.
- A willful act which results in the defacing, destruction, or theft of school property or the property of others.
- Possession, distribution or use of alcoholic beverages.
- Directing abusive, discourteous, profane or insulting language towards members of the College staff or its representatives.
- Continued cheating/plagiarism.
- Possession of weapons (with the exception of a firearm, as stated below) and/or hazardous materials, which places anyone within the school community at risk.

F. Expulsion from school will apply, defacto, to the following cases:

- The direct or indirect involvement in the use, sale, distribution or consumption of illegal stimulants, or non-authorized use of prescription drugs.
- Use of a weapon and/or a hazardous material. (A weapon is defined as any object used with the intent or threat of causing bodily harm.)
- Possession of a firearm.
- Involvement in a flagrantly immoral or socially distasteful act.
- Inappropriate use of technology.
- Harassment.
- Threats.
- Defamatory libel.
- Sexual harassment directed toward any member of the school community.

Expulsion, as defined in sections E and F may be:

- a) effective immediately,
- b) effective at the end of a semester.

The decision to expel a student for breaching one of these rules is the exclusive prerogative of the College's Headmaster. The Headmaster shall convene a meeting with the parents and the student to give notice of the decision and rationale (evidence, rules, jurisprudence). In the event that the student and/or the parents feel that the procedures and/or the rules were improperly applied, the family may ask that the decision to expel be examined by the **Review Board**.

The **Review Board**, respecting confidentiality, will ensure that the procedure is thorough and that the application of the rules is correct. The Review Board will require unanimity to reverse the Headmaster's decision. The Review Board is composed of two parents, one faculty member, one administrator and one Board member other than the individuals previously mentioned.

Notice requesting a review must be sent by registered mail, postmarked within 48 hours of the Headmaster's decision, addressed to the College to the attention of the Review Board. The parent(s) will present personally and/or in writing to the administrator on that Board, the basis upon which he or she is requesting a review. The Review Board shall convene, review the case based on the representation made to the administrator by the parties involved and render a decision within 5 school days of the receipt of the request to review.

*Harassment includes:

- a) any action, intentional or not, including action of a sexual nature, directed at an individual or group by another individual or group who knows or ought to know that his/her action is unwanted;
- b) any implied or explicit bribe, and/or threat of reprisal
- c) any behaviour, verbal or physical, which creates an intimidating or hostile atmosphere,
- d) any action, intentional or not, that demeans an individual or group;
- e) any perceived threat to or abuse of personal property.

Harassment, which in some cases may be described as bullying, can be psychological or physical and may include, but is not limited to such unacceptable behaviour as:

- a) unwelcome leering or staring;
- b) unwelcome racial slurs, epithets, threats, verbal abuse, derogatory comments or degrading descriptions;
- c) unwelcome communication including that about an individual's body, attire, racial origin, or overly personal comments;
- d) unwelcome invasion of an individual's privacy;
- e) unwelcome jokes, stories, drawings, pictures or gestures;
- f) the spreading of malicious rumors;
- g) suggestions or demands for payment accompanied by implied or explicit threats (taxing);
- h) cornering or blocking normal movements;
- i) misuse of power or position;
- j) stalking.

4. West Island College Uniform

At West Island College, we believe that a uniform encourages students to recognize each other for whom they are and not for whom they appear to be. The policy also allows the community at large to recognize our students as a group of young people who share a common ideal and goal: “The Pursuit of Excellence”.

All students are expected to arrive and depart from school in the school uniform. Students will also wear the uniform at all times during the school day, unless a note is supplied by parents explaining why the uniform is not being worn and approved by the administration. Prior to, at lunch, or at school dismissal students are permitted to leave their blazers in their lockers. Students who **consistently** arrive at school out of uniform **will be sent home**.

Formal Uniform

Formal Uniform Junior School (grades 7, 8 and 9)

Junior students wear a green blazer, with grey pants for boys and a grey kilt or skort for girls, over a white shirt and a school tie. Long or short sleeved shirts are both acceptable. A crested dark green sweater or sleeveless vest is also available, but optional. Boys wear grey or black socks, girls wear grey or black knee socks or tights and both wear any polishable, black dress shoes.

Formal Uniform Senior School (grades 10, 11)

Senior boys wear grey pants, a white shirt, a school tie and a crested black blazer and grey or black socks with black dress shoes. A black sweater is also available, but optional. Senior girls wear a tartan kilt with a black crested blazer, white shirt, a school tie, green or black hose, tights or knee socks and black dress shoes.

Summer Uniform

With the approval of the Board of Governors, the college is implementing a summer uniform. This summer uniform is sanctioned during certain periods of time during the academic year (see school calendar). The summer uniform is optional (students may wear the formal uniform during this period if they wish). Wearing of the summer uniform is a privilege and can be revoked if students aren't respecting the summer dress code.

Summer Uniform Junior School (grades 7, 8 and 9)

Junior students wear grey pants for boys and a grey kilt or skort for girls and a crested West Island College polo shirt, which must be purchased from our official uniform supplier, Top Marks. Boys wear grey or black socks, girls wear grey or black knee socks or tights and both wear any polishable, **black dress shoes**.

Summer Uniform Senior School (grades 10, 11)

Senior boys wear grey pants, grey or black socks with black dress shoes and a crested West Island College polo shirt, which must be purchased from Top Marks. Senior girls

wear a tartan kilt, green or black hose, tights or knee socks, black dress shoes and a crested West Island College polo shirt, which must be purchased from our official uniform supplier, Top Marks.

Physical Education

Hunter green crested athletic shorts, a crested grey tee-shirt, white socks, and proper white soled athletic footwear are expected from all students for physical education classes, team practices and intramural competitions. Though optional, hunter green crested sweat pants and sweat shirts are recommended for outdoor activities in late fall and early spring.

Outer Garment

Rather than sanction a uniform outer garment, the College has chosen to select only a uniform colour. All outer garments, spring, fall and winter, must be black, forest green or grey.

• ***Uniform***

Students must wear the College's uniform at all times during the day, **including travel to and from school.**

R = REQUIRED **S** = SUGGESTED **O** = OPTIONAL **TM** =
Must be purchased from the official supplier (**TOP MARKS**)

ITEM
REQUIRED/SUGGESTED/OPTIONAL

WHITE SHIRT/BLOUSE, button-down collar	R	
ALL-WEATHER COAT	O	
V-NECK PULLOVER SWEATER, hunter green, crested (Juniors only)	O/S	TM
V-NECK PULLOVER SWEATER, BLACK , crested (Seniors only)	O/S	TM
V-NECK PULLOVER VEST, hunter green, crested (Juniors only)	O	TM
PHYSICAL EDUCATION T-SHIRT, grey, crested	R	TM
PHYSICAL EDUCATION SHORTS, hunter green, crested	R	TM
PHYSICAL EDUCATION SOCKS, white	R	
PHYSICAL EDUCATION TRACK SUIT, hunter green, crested	O	TM
PHYSICAL EDUCATION GOLF SHIRT, white, knitted collar, crested	O	TM
SHOES black polishable leather	R	

Boots/sandals/running shoes are not permitted.

Junior Boys

CRESTED WHITE POLO SHIRT	O	TM
BLAZER, hunter green, crested	R	TM

TIE, Junior School (purchased at WIC)	R	
PANTS, grey, dressed	R	
SOCKS, grey or black	R	
BLACK LEATHER BELT	R	

Junior Girls

CRESTED WHITE POLO SHIRT	O	TM
BLAZER, hunter green, crested	R	TM
TIE, Junior School (purchased at WIC)	R	
KILT, grey, hemmed between 3" of the knee (above or below)	R	TM
or		
SKORT, grey, hemmed between 3" of the knee (above or below)	R	TM
PANTS, grey, (MUST BE PURCHASED FROM TOP MARKS)*	O	TM
KNEE SOCKS or TIGHTS, grey or black	R	

Senior Boys

CRESTED WHITE POLO SHIRT	O	TM
BLAZER, black, crested	R	TM
TIE, Senior School (purchased at WIC)	R	
PANTS, grey , dressed	R	
SOCKS, grey or black	R	
BLACK LEATHER BELT	R	

Senior Girls

CRESTED WHITE POLO SHIRT	O	TM
PANTS, grey, (MUST BE PURCHASED FROM TOP MARKS)*	O	TM
BLAZER, black, crested	R	TM
TIE, Senior School (purchased at WIC)	R	
KILT, plaid, hemmed between 3" of the knee (above or below)	R	TM
KNEE SOCKS or TIGHTS, green or black	R	

* Please note that pants for girls are **not** permitted during the Formal Uniform periods (please see the school calendar)

- *Uniform Supplier*

School Uniforms

a) Supplier of New Uniforms

With the exception of school ties which may be purchased from the school the first day of classes, all other school clothing must be purchased from the official supplier:

Top Marks Sports Wear
5760 Ferrier Street
Town of Mount Royal, Que.
H4P 1M7

Tel: 344-5454 Fax: 344-5350

You should receive order forms directly from this company. Parents are reminded to check the uniform description before purchasing any item elsewhere other than from the official supplier.

b) Used Uniforms

A team of parent and student volunteers organize an annual sale of used uniforms during the month of June of each year. The sale is organized to coincide with the Used Textbooks Sale. Typically garments that are sold at this sale are blazers and kilts.

5. Policies

• Promotion Policy

Promotion to the next level of study at West Island College is based upon three criteria:

- ⇒ successful completion of French, English, Mathematics and Science courses at each level
- ⇒ consistent respect for school rules
- ⇒ sustained and productive effort in all subject areas.

• Absentee Policy

*** *Absent, late arrival or early departure.***

It is the policy of the school to verify all students' absences on a daily basis. In order to facilitate this procedure, we ask parents to call the school if the student is to be absent, late or leaving during the day. Please make this call promptly, preferably before 08:30. Also please note that if students are arriving or leaving outside normal hours, they and their parents are requested to do so from the main entrance checking in or out with the receptionist.

*** *Granting Credits***

Since there is a direct relationship between attending class and succeeding in a course, the College wishes to underscore the significance of the relationship.

Course credit may be withheld if a student misses more than 30 hours in any course. After 10 hours of absences, teachers will remind both students and parents of this policy. After 20 hours of absences a meeting to assess the situation may be set-up between the student, the parents and the Headmaster. After 30 hours of absence, and unless such absence is justifiable, the Headmaster may refuse to grant credit(s).

* ***Examinations***

The following procedure is applied when students are absent from a scheduled school examination in any subject. Justifiable reasons for missing an examination are medical or religious.

Students who are absent due to *confirmed illness or religious reasons*.

- ⇒ If still viable, the student will be requested to write the examination upon return to school. This may take place on the date of his or her return.
- ⇒ If the examination content is compromised, it will not be administered and a grade determined based on the results to date and/or perhaps an increased weighting of the next evaluation.
- ⇒ In the case of a final examination, the director of studies must be contacted to determine procedures. All illnesses must be accompanied by a medical certificate;

Students who are absent for *other than confirmed illness or religious reasons*.

- ⇒ In the case of extended absence, the student may be granted an “Incomplete Mark”. Please refer to Incomplete Mark Policy.
- ⇒ Students who are absent without a justifiable reason will receive 0% or “Incomplete” for the missed examination. e.g. A student who misses a term exam due to an extended family holiday and for which the college was advised may receive “Incomplete”. A student who simply avoids the examination will receive 0%.

* ***Assignments***

School rules dictate that all assignments must be handed in on time. A maximum of 20% will be deducted for assignments, which are one day late. Professional discretion will apply for additional late penalties.

The student may be detained to complete the assignment.

If a student is ill on the day an assignment is due, every effort should be made to drop the work off at school (a car pool partner, sibling, friend).

If this is not possible, a note from a parent explaining the absence when the child returns to school, will override the deduction of marks.

- **Incomplete Mark Policy**

A student receives an incomplete mark (PN= Pas de note) if it is deemed that there are not enough marks available to accurately evaluate the student's performance.

A student who receives an incomplete mark is excluded from the President's Honour Roll for the term in question. All marks that were recorded by the teacher for the incomplete term are tabulated and included in the final mark of the course.

- **Examination Environment Policy**

Each student must follow the directives specific to each exam. Any breach to these directives may lead to a zero and a suspension for cheating. It is also important to note that students are not allowed to talk at any time during an exam. If a student is caught talking, his/her exam copy will be confiscated at that point and corrected as is, minus 20%.

- **Detention Policy**

A detention is assigned via a "Carnet de l'élève" (See Communication) and thus a parent must sign to acknowledge that they are aware of the infraction and the date of the detention. The student must bring the signed copy of the "Carnet de l'élève" to the detention and submit it to the supervisor. Detentions are held on Fridays from 3:00 p.m. until 5:00 p.m. Detentions must be served on the assigned Friday unless that date causes undue hardship. If such is the case, a note from the parents must be sent to the administrator in charge of the student, at which time, a mutually agreeable alternate date will be designated.

- **Senior High School Course Load Policy**

Students in the Senior High School are expected to enrol in a full course load. Study periods (spares) are not, generally, available to students at any level. We want to make the most of our available instruction time.

- **Visitors Policy**

For security reasons, no visitors are allowed in the school or on the school grounds during the regular school day. (Exceptions to this would be for a school sponsored public event or exhibit) Requests should be directed to the Headmaster or to the Director of Student Services. If permission is granted, visitors will be issued a special authorization pass, which must be worn for the duration of their stay.

- **Homework Time**

There is not a policy for maximum homework time, however we believe that it is important that students form good study habits and thus students can anticipate being responsible for daily reading and an additional 60+ minutes of homework at the grade 7 & 8 levels, and 90+ at the higher grades. The teacher may discipline students who do not complete their homework unless they can present a written and justifiable excuse supported by a note from a parent or guardian.

- **Evaluation Coordination Practices**

Teachers at West Island College attempt to coordinate examinations and assignment due dates by using a coordination calendar.

- **Leaving School Grounds**

Secondary V students are allowed to leave school grounds at lunch time if their parents have filled the appropriate waiver form. Secondary IV students have the same privileges on Mondays and Wednesdays only. Secondary I to III students must remain on school grounds at all times during the school day. Leaving school property at recess is not permitted for any student, at any grade level. Leaving school property for instructional purposes, i.e. Outreach, Physical Education, etc., is allowed only in conjunction with specific curriculum requirements.

- **Student Drivers, Parking, Bicycles**

Students are welcomed to use the school parking facilities as long as they park in the designated area and drive in a safe and courteous manner on and around school grounds.

- **Smoking**

West Island College is a non-smoking school. Students may not smoke in the school, on the school grounds, near the school, nor at any school-related activity. Please refer to school rules.

- **Snow Days or School Closing**

If and when the school must be closed due to a winter storm or for another reason, every attempt is made to have the cancellation broadcast over the airwaves prior to 07h00.

Radio stations to monitor are:

FM: CFQR 92.5 MIX 96 AM: CIQC 600 CJAD 800

VII - Services

1. Extra-Help

A feature in which the school prides itself is its commitment to provide an individual student with as much academic reinforcement as possible to assist the student in his/her pursuit of excellence. Students are encouraged to apply study methods as recommended by their teachers and to make use of extra-help services. Those identified as needing extra-help are directed to avail themselves of it.

The faculty approaches the implementation of this school function with professionalism and dedication. We ask your co-operation in ensuring that student commitments to extra-help and/or, peer-tutoring sessions, supplementary assignments, and study methods are honoured.

2. Tutoring

- ***Peer Tutoring***

Above and beyond extra-help services, peer-tutoring arrangements may sometimes be arranged for students who have demonstrated commitment and need. Peer-tutoring services are subject to teacher recommendation. Peer tutoring is organized through the Guidance Department.

- ***Professional Tutoring***

All too often parents will arrange for professional tutoring without prior consultation with the school. Parents are advised that this practice is not recommended by the college. On occasion, this practice has even been counter productive and thus a hindrance to student progress. This occurs when the student, as a result of having a tutor, fails to attend extra help sessions, completes homework poorly, and/or rarely asks questions to the teacher since he/she begins to rely on the convenience of a tutor. If a tutor is being considered, please consult with the student's teacher and the level administrator.

In the same vein, occasionally parents have requested that a child's teacher be engaged for private tutoring. West Island College teachers may not tutor their own students for financial gain as this may be construed as a conflict of interest.

3. Study Hall

Following the first term report card, any student who fails a subject that is taught three periods or more per week and/or who demonstrated a weak effort grade in that subject, may be required to attend Study Hall.

The objective is to provide 75 min. of supervised homework and thus hopefully encourage the student's acquisition of a proper study routine which will help ensure success.

Study Hall takes place from 15h15 to 16h30 after school. Students are required to do their homework in a quiet setting. A teacher is available to help students and control the environment and attendance.

Students who are not obliged to go may also request to join the program by simply making a request to their level administrator.

Parents of students involved in this program will be contacted by their child's level administrator.

4. Guidance

Ms. Kim Wolfe is the school's Guidance Counselor. Students are encouraged to make appointments to see her whenever they have concerns or questions regarding issues such as overcoming academic difficulties (exam anxiety, poor study skills etc.), information

regarding educational or career opportunities, as well as personal difficulties. According to the Quebec Civil Code, parents of children under the age of fourteen must consent to counseling services before any such services are provided. In such an event, a consent form will be sent home to be signed and returned before such services are to begin.

5. Library Resource Centre: Computer Services

The library at W.I.C. is known as the Resource Centre. The Resource Centre houses one of our computer laboratories, and is connected to fast access internet and is available to West Island College students during Resource Centre hours: 8:00 – 17:00. Students that use the Resource Centre are expected to bring and dedicate their time to school-related work only. Games and online chatting is not tolerated.

The Resource Centre, just like the rest of the school, is also equipped with a WI-FI connection that allows wireless networking with laptops that are available to students. Some computers are also equipped with digital video editing software to provide multi-media capabilities.

6. Books :

• New Textbooks

Students purchase their own textbooks. An appropriate order form from our textbook supplier, Librairie Guérin, is distributed annually during the students' June final exams and mailed home to all new students. To order new textbooks, simply follow the instructions indicated on the order form.

As a rule of thumb, students should expect to keep their English and French reference books from year-to-year and sell several of their hard-cover textbooks.

We urge all parents to encourage their children to cover, identify, and maintain textbooks with care for they are expensive and can be resold at year's end if they are in good condition. All too often, a textbook with an anticipated three year life span is needlessly abused or neglected and loses its resale value. Note that the College changes its official course texts from time to time. As a result, there is no guarantee that a text will be eligible for re-sale.

Librairie Guerin's address:

4560, rue Saint-Denis

Montreal, Quebec

H2J 2L3

Tel.: (514) 849-1112

Fax.: (514) 849-6360

• Used Textbooks

In June of each year, senior students from the upcoming year's Grad Committee assist other students who wish to sell their old textbooks by arranging a sale. Parents and students are

advised prior to the sale as to the procedures to sell and purchase.

7. School Supplies

Certain school supplies are included with the school fees and will be distributed in class as the need arises. These include:

- 1 lock (for new students)
- various art supplies
- an agenda
- calendar
- laboratory needs
- photocopies provided from school
- school photo and identification card

Other school supplies such as paper, exercise books, binders, pens and pencils, etc., are not included in the school fees. It is advised that students wait until meeting with their teachers before making purchases as some courses will require specific exercise books, others will require binders, etc. To begin the year, the purchase of a few one inch binders is appropriate. All students should also have unilingual French and English dictionaries, as well as a French verb conjugation reference book.

8. Student Photographs

Students have their photographs taken annually for their school I.D. cards. Along with the I.D. card, a photo package is included. These packages are included in the school fees and are typically ready well in advance of the gift-giving holiday season. The date for this year's session is Thursday, August 30th.

9. Transportation

Since the school's location is convenient to the major arteries in the West Island, it attracts a number of car pool commuters. There is, in addition, excellent S.T.C.U.M. bus service. Students can catch the bus #208 directly in front of the school.

10. S.T.C.U.M. Bus Passes

The S.T.C.U.M. representative will be at the school in the fall to take pictures of all students desiring a bus pass which entitles them to the reduced student fare. Students with a bus pass from the previous school year may continue to use the pass until October 31. Students are reminded that their school ID cards, or their uniform are not accepted in place of the bus pass. A memo to parents and students will be issued regarding details of how to obtain the new pass.

11. Cafeteria Services

Students have access to a full hot and cold meal service in the school cafeteria. The service is available from 7:30 a.m. to 1:00 p.m., although there may be extended service on some days. A variety of fruit juices, muffins and homemade snacks are also available. The meal plan is compulsory for new students. The weekly meals are listed in the Au Courant online.

12. Lost & Found

Two lost & found boxes are located in the building. Small valuables are kept at the reception desk or gymnasium office; clothing left behind in the locker rooms, and items found throughout the building are placed on a table located at the south east entrance of the school.

VIII - The School Year

1. The School Day

Daily Assembly

A five minute school assembly takes place every day. The goal of this assembly is to boost school spirit by improving communication throughout the school.

School Hours

Officially the building opens at 7:30 a.m. and closes at 6:00 p.m. Students remaining in the school after 3:30 p.m. are required to remain in the area that is assigned to the activity in which they are participating. Students who are waiting for their activity to begin, or are simply waiting for a ride home must stay in the cafeteria. Students wishing to study quietly may do so in the resource centre, however strict silence must be observed.

All students not officially involved in activities after 6:00 p.m. must leave the building.

Semestered Timetable

A few junior courses and all Secondary IV and V courses are taught on a semestered basis. This means that the timetable is similar to that of a college or university. During the course of a year, students complete the same number of courses as in a non-semestered system. The year, however, is broken into two semesters. A student will take the first half of his/her courses during the first semester (August to January), write his/her final exams, and the second half of their course load during the second semester (February to June).

For more information, please refer to section II (Programme of study-page II-7).

Timetable Flip

The timetable is based on a five day fixed Monday through Friday rotation. It is designed as such in order to accommodate our experiential programs: Outreach, Educational Partnerships, and Senior Phys-ed., which necessitate scheduling around the real world and not vice-versa.

The timetable is changed entirely at the beginning of each semester: August and February. We provide variation in daily scheduling by tumbling or flipping the timetable the 2nd term of each semester. This is done to shake up the routine a little so that students do not have the same course each Friday afternoon. The “flip” implies that the timetable is inversed on each Friday. That is 1st period becomes last period, 2nd period becomes 5th, etc.

DAILY TIMETABLE

TIME

7:55	First bell, beginning of the school day (5 minutes before period 1)
8:00	Beginning of period 1
8:54	End of period 1
9:02	Beginning of period 2
9:56	End of period 2 / Beginning of recess
10:11	Beginning of period 3
11:05	End of period 3
11:10	Beginning of period 4, Junior Assembly and Junior Lunch
12:04	End of period 4
12:09	Beginning of period 5, Senior Assembly and Senior Lunch
13:03	End of period 5
13:08	Beginning of period 6
14:02	End of period 6
14:10	Beginning of period 7
15:04	End of period 7

2. The School Calendar: Special Events

The official school calendar is printed at the end of June and given with the final report. Parents are encouraged to use this calendar as a family organizer. Numerous special events and important dates are entered on the calendar to serve as a reminder of events to come.

For your convenience, a listing of typical dates and events to watch for follows:

Special Events and Dates

- Orientation: Welcome Week
- Parent Information Evenings
- Board of Governors Meetings
- The Annual General Meeting
- Outdoor Education Sec I - V
- Public Speaking: French & English
- Tournaments
 - Sports
 - Debating
 - Mathematics
- Spirit Days
- Expo - Science
- Expo - Culturelle
- Ceremonies
 - Opening
 - Closing
 - Graduation
- Qualifying Entrance Examinations
- Open House
- Parent Teacher Interviews
- Au Courant Issues
- Vacation Days
- Professional Days

3. The 2008-2009 Year at a Glance

Major Holidays & Events

You may be anxious to know some of the major holidays, and events. They are:

Oct 31

Flip Friday (Inverse Fridays all of term 2)

Nov 5	Sec II Alvin Powell Guest Speaker (Kim)
November 12	Faculty Meeting (No After School E.C.A's)
Nov. 14	B-Ball Tournament
Nov. 15	B-Ball Tournament
Nov 19	Sec I Field Trip: Salon du livre 8:00-12:00
November 19, 20	Parent Teacher Interviews, Early Dismissal Nov.20, (12:00)
November 20	Sortie scolaire: Salon du livre: Secondaire 1 8h10-11h30
November 21	Professional Day: Teachers Convention
November 24	Sortie scolaire: Salon du Livre - sec. 2 12:00-15:00
Nov. 28	B-Ball Tournament
Dec 4	MELS Français V examen 8 :30- 12 :00
December 11 th	Sec III English Public Speaking
December 12	Professional Day, Variety Show (Confirmed)
Dec. 16	Concours d'art oratoire –sélection des candidats de sec. 5 – cafétéria
Dec. 17	Holiday Concert
December 22 - January 2	Holidays, Early dismissal 12:00 Dec 19
January 12 -16	Exams Sec V
January 13 -16	Exams Sec I – IV
January 16	End of term 2
January 19, 20	Professional Days: Staff Meeting 10:00
Jan 20-23	Sec III Outdoor ed.
Jan 30	Reports Issued TBC
Feb 10	QAIS Intermediate Public Speaking Contest
Feb. 10	Concours d'art oratoire – sec. 2 cafétéria
Feb. 13	Carnival
February 17	Faculty Meeting (No After School E.C.A's)
Feb 23	Sec I English Public Speaking
Feb 23	Mid-term reports issued TBC
Feb 24	Concours d'art oratoire – sélection des candidats de sec4 - cafétéria
February 25, 26	Parent Teacher Interviews
February 27	Professional Day
March 2 – 6	Holidays
Mars 11	Concours d'art oratoire – sélection candidat QAIS -
March 16	Guest Speaker Sec. I, II & III
March 19	Faculty Meeting (No After School E.C.A's)
March 25	QAIS Senior French Public Speaking Event at WIC
March 25	QAIS Junior English public speaking at Bialik
March 27	End of term 3
April 3	Reports Issued / Flip Friday
April 6 - 13	Holidays
April 20	Faculty Meeting (No After School E.C.A's)
April 23	Sec V English Public Speaking
May 4+5	Sec III Theatre production
May 8 or 29	Mozambique Survivor TBC
May 15	Professional Day
May 15-17	Sec V NYC Trip
May 18	Holiday
May 20-22	Sec II Outdoor ed
May 21, 22	Tentative dates for Sec III: Ottawa, Sec IV Quebec City
May 26	Sec IV MELS Math exam Competency 2
May 28	Faculty Meeting (No After School E.C.A's)
June 2	Grad ceremonies
June 3	Sec V Tutorials
June 4	MEL English V exam Part2 / Sec V tutorials
June 5	Closing Ceremonies
June 8 - 23	Exams
June 24	Holiday
June 25 – 30	Professional Days
June 30	Reports Issued TBC

